

The Ryanodine Receptor Calcium Channel of β -Cells

Molecular Regulation and Physiological Significance

Md. Shahidul Islam

The list of Ca^{2+} channels involved in stimulus-secretion coupling in β -cells is increasing. In this respect the roles of the voltage-gated Ca^{2+} channels and IP_3 receptors are well accepted. There is a lack of consensus about the significance of a third group of Ca^{2+} channels called ryanodine (RY) receptors. These are large conduits located on Ca^{2+} storage organelle. Ca^{2+} gates these channels in a concentration- and time-dependent manner. Activation of these channels by Ca^{2+} leads to fast release of Ca^{2+} from the stores, a process called Ca^{2+} -induced Ca^{2+} release (CICR). A substantial body of evidence confirms that β -cells have RY receptors. CICR by RY receptors amplifies Ca^{2+} signals. Some properties of RY receptors ensure that this amplification process is engaged in a context-dependent manner. Several endogenous molecules and processes that modulate RY receptors determine the appropriate context. Among these are several glycolytic intermediates, long-chain acyl CoA, ATP, cAMP, cADPR, NO, and high luminal Ca^{2+} concentration, and all of these have been shown to sensitize RY receptors to the trigger action of Ca^{2+} . RY receptors, thus, detect co-incident signals and integrate them. These Ca^{2+} channels are targets for the action of cAMP-linked incretin hormones that stimulate glucose-dependent insulin secretion. In β -cells some RY receptors are located on the secretory vesicles. Thus, despite their low abundance, RY receptors are emerging as distinct players in β -cell function by virtue of their large conductance, strategic locations, and their ability to amplify Ca^{2+} signals in a context-dependent manner. *Diabetes* 51:1299–1309, 2002

Physiological regulation of insulin secretion by glucose and incretin hormones involves oscillatory changes in the cytosolic free Ca^{2+} concentration ($[\text{Ca}^{2+}]_c$) in β -cells. The subcellular location, magnitude, and form of such $[\text{Ca}^{2+}]_c$ changes are

From the Department of Molecular Medicine, Karolinska Institutet, Department of Endocrinology, Karolinska Hospital, Stockholm, Sweden.

Address correspondence and reprint requests to Md. Shahidul Islam, Associate Professor, Department of Molecular Medicine, Karolinska Institutet, Department of Endocrinology, Karolinska Hospital L1:02, S-171 76 Stockholm, Sweden. E-mail: shahidul.islam@molmed.ki.se.

Received for publication 6 November 2001 and accepted in revised form 14 January 2002.

$[\text{Ca}^{2+}]_c$, cytosolic free Ca^{2+} concentration; $[\text{Ca}^{2+}]_m$, mitochondrial Ca^{2+} concentration; CICR, Ca^{2+} -induced Ca^{2+} release; ER, endoplasmic reticulum; FDP, fructose 1,6-diphosphate; K_{ATP} , ATP-sensitive potassium channel; IBMX, 3-isobutyl-1-methylxanthine; IP_3R , IP_3 receptor; NO, nitric oxide; PDE, phosphodiesterase; PKA, protein kinase A; RY, ryanodine.

determined by Ca^{2+} fluxes through several Ca^{2+} channels as well as a dynamic interplay between multiple Ca^{2+} -handling systems and signaling molecules (1). In this respect the intracellular Ca^{2+} pools of β -cells play critical roles. Recent studies demonstrate that these Ca^{2+} pools participate in amplification of Ca^{2+} signaling (2). Ca^{2+} fluxes across these Ca^{2+} pools regulate plasma membrane ionic events and thereby ensure rhythmic changes in membrane potential, $[\text{Ca}^{2+}]_c$, and pulsatile insulin secretion (3,4).

Glucose-stimulated $[\text{Ca}^{2+}]_c$ increase in β -cells requires Ca^{2+} entry through Ca^{2+} channels that are gated by voltage. These channels are located on the plasma membrane and are thus easy to study by the patch-clamp technique. Located deeper inside the cell, and thus more difficult to study, are two other groups of Ca^{2+} channels that are gated by Ca^{2+} rather than by voltage. The names of these channels, IP_3 receptor (IP_3R) and ryanodine (RY) receptor, do not underscore their Ca^{2+} channel function or their gating mechanism. RY receptors are so named because a plant alkaloid ryanodine binds to these channels with nanomolar affinity. These are huge conduits for Ca^{2+} release, abundant in muscle cells and some neurons. There is now considerable evidence that such channels are present in β -cells too (5). A critical property of RY receptors is that cytosolic Ca^{2+} can activate these channels. In principle, such Ca^{2+} -induced Ca^{2+} release (CICR) can provide a mechanism for amplification of Ca^{2+} signals elicited by voltage-gated Ca^{2+} channels or the IP_3Rs . However, despite a decade of study, there is still no consensus among islet researchers on the role of RY receptors in stimulus-secretion coupling, and some investigators even doubt that such channels are present in β -cells.

I shall outline what we have learned so far about the significance of RY receptors in β -cells and discuss open issues that require more research. I shall briefly describe some distinct properties of the RY receptors and the usage of relevant pharmacological tools to illustrate potential difficulties involved in studying these channels. Finally, I shall highlight some properties of these channels that are attractive from the viewpoint of stimulus-secretion coupling. I shall try to strike a balance between caution against over-interpretation and anticipation of the direction in which the field may head.

INTRACELLULAR CALCIUM CHANNELS OF β -CELLS.

The two families of intracellular Ca^{2+} channels. IP_3Rs and RY receptors, the two main families of intracellular

TABLE 1
Summary of studies that present results consistent with the view that insulin-secreting cells possess RY receptors

Insulin-secreting cells	Main methods/pharmacological tools	Reference
RINm5F cells	Thimerosal, permeabilized cells	(5)
	Fura-2, caffeine	(24)
	RT-PCR	(30)
INS-1 cells	Fura-2, caffeine	(25,26)
	ER aequorin, 4-chloro- <i>m</i> -cresol	(120)
	Western blot	(25)
βTC3 cells	RT-PCR	(19)
	RNase protection assay	(16)
	Fura-2, ryanodine	(66)
MIN6 cells	Vesicle-targeted aequorin, caffeine,	
	cADPR, 4-chloro-3-ethylphenol	(22)
	Immunocytochemistry	(121)
	Fluorescent ryanodine	(121)
	ER-targeted cameleon, caffeine	(82,121)
	Fluorescent ryanodine	(82)
HIT-T15 cells	Caged cADPR	(82)
	Fura-2, caffeine	(19,64)
	Fura-2, 4-chloro- <i>m</i> -cresol	(64)
	RT-PCR	(27)
Mouse islets	Fluo-3, Ruthenium red, X-ray microanalysis	(114)
	Fura-2, caffeine	(59)
	RT-PCR	(18)
	RNase protection assay	(16)
	Microsomes, ⁴⁵ Ca ²⁺ , theophylline	(46)
Mouse β-cells	Fura-2, caffeine	(16,55)
	Fura-2, caffeine, ryanodine	(67)
	Fura-2, 4-chloro-3-ethylphenol	(16)
	Fluo-3, caffeine	(58)
	Fluorescent ryanodine	(19)
	⁴⁵ Ca ²⁺ efflux, theophylline	(10)
Rat Islets	Microsomes, fluo-3, cADPR, ryanodine	(15)
	RT-PCR	(19)
	Fura-2, caffeine	(55,72,122)
Rat β-cells	Fluo-3, caffeine, ryanodine, NO	(17)
	Fluorescent ryanodine	(19)
	Fluorescent ryanodine imaging	(19)
Human β-cells	Fluorescent ryanodine imaging	(19)
	Quantitative ryanodine-binding	(19)

Ca²⁺ channels, share some structural and functional similarities. IP₃Rs of β-cells have been reviewed elsewhere and will be mentioned here only briefly (6). cDNAs for three RY receptors have been cloned. RY₁ is present mainly in skeletal muscle. RY₂ is abundant in heart but is also the major isoform in the brain. RY₃ is present at low levels in many cells. The three genes of human RY receptors RYR1, RYR2, and RYR3 have been mapped to chromosome positions 19q13.1, 1q42.1–1q43, and 15q14-q15, respectively. Two putative alternative splicing sites have been postulated for RY₂ mRNA. Homologues of mammalian RY receptors and IP₃Rs are present in *C. elegans*, *D. melanogaster*, and Zebrafish. IP₃Rs and RY receptors probably arose by a gene duplication event in invertebrates. The phylogenetic tree of RY receptor family suggests that the three vertebrate RY receptor genes were probably generated at the same time (7). However, one analysis suggests that RY₂ may be the original vertebrate form of RY receptors (8). The three isoforms probably arose by two gene duplication events in vertebrates (9).

Discovery of RY receptor of β-cells. Investigators considered the possibility that β-cells might have RY receptor-like channels when they found that theophylline releases Ca²⁺ from intracellular stores (10). After the discovery

that IP₃ releases Ca²⁺ from the endoplasmic reticulum (ER) of β-cells, studies of this channel dominated the field (11). However, IP₃ can release only ~50% of the Ca²⁺ sequestered into the ER (11). It was a possibility that the IP₃-insensitive ER Ca²⁺ pool may be equipped with the RY receptor (5). Thimerosal, a sulfhydryl-oxidizing agent that activates RY receptors, proved useful to test this hypothesis.

In RINm5F cells and β-cells obtained from *ob/ob* mice, thimerosal released Ca²⁺ from the IP₃-insensitive ER Ca²⁺ pool (5,12). The release was potentiated by caffeine, suggesting that a RY receptor might be involved. While thimerosal can activate some IP₃Rs, the type 3 IP₃R that is the predominant isoform in RINm5F cell and rat β-cells (13) is not activated by thimerosal (14). Subsequent studies that demonstrated Ca²⁺ release by ryanodine from islet microsomes (15) and by caffeine from ER of intact β-cells (16) strengthened the view that RY receptors are present in β-cell.

Accumulating evidence for RY receptors in β-cells. RY receptors have been demonstrated in a variety of insulin-secreting cells (Table 1). Such studies used pharmacological tools (5), endogenous ligands (15,17), molecular techniques (16,18,19), and quantitative ryanodine-

binding (19). Some studies, however, imply total lack of RY receptors in β -cells (20,21). Contradictory reports as to whether β -cells have RY receptors are common even when the same investigators are involved (16,20,22,23). This may be due to low abundance of these channels, differences in cell types, or methods used. Thus, some clones of RINm5F cells have RY receptors (5,24) whereas others do not (25). β -Cells from some colonies of *ob/ob* mice have RY receptors (16) whereas others do not (18). When the same cell types are used, caffeine is more likely to release Ca^{2+} from the ER of intact cells (25,26) than of permeabilized cells (23), suggesting that the permeabilization results in the loss of one or more regulatory factors.

The most abundant RY receptor mRNA in β -cells is that of RY_2 , as indicated by RNase protection assay and RT-PCR analysis (16,18,19). The probes and primers used in these studies target different regions of RY_2 cDNA that code for the highly conserved membrane-spanning and COOH-terminus portions of RY_2 . It is not known whether the β -cell RY_2 mRNA is identical to that of the heart or to one of its alternatively spliced transcripts. At the protein level, the presence of RY_2 receptors has been demonstrated by Western blot of membranes from INS-1 cells (25). In human β -cells, the receptor has been demonstrated by quantitative ryanodine-binding (19). Very low levels of RY_1 mRNA have been observed in βTC3 cells, and RY_3 mRNA is expressed in HIT-T15 cells (27). Thus, on the balance of current evidence, the existence of RY receptors in β -cells appears to be well documented.

RY receptor density in β -cells. An important issue is whether the density of RY receptors in β -cells is high enough to be of functional significance and how it compares with that of IP_3Rs in these cells. The level of RY_2 in rodent β -cells or cell lines as compared with that in heart or brain is low. In RNase protection assay, mouse βTC3 cells show a band corresponding to RY_2 mRNA, which is $\sim 1,000$ -fold less than that in heart (16). In INS-1 cells, RY_2 protein is ~ 10 times less than that in brain (25). However, comparisons with heart or brain may be misleading since these tissues contain high amounts of the protein. RY_2 level in β -cells may be comparable to that in pancreatic acinar cells, kidney, endothelial cells, and adrenal chromaffin cells (28,29). The level of RY receptors in the glucose-insensitive RINm5F cells as evidenced from RT-PCR (30), Western blot, and functional studies is low (25). Nevertheless, these cells were useful for providing the first indications of the existence of RY receptors in β -cells (5). INS-1 cells, which are related to RINm5F cells but are glucose-responsive, have more RY receptors (25,26).

In *ob/ob* mice, leptin deficiency leads to profound disturbances with accompanying changes in the islets. These mice are used as a model for studies in obesity and diabetes. Paradoxically, islets from *ob/ob* mice are used for "physiological" studies. This is because *ob/ob* islets are large and consist of 90–95% β -cells. These β -cells respond "normally" to elevated glucose with a release of insulin. However, islet-phenotype in these mice depends on the genetic background on which the *ob* gene is expressed. Islets from a noninbred colony of *ob/ob* mice express RY_2 at low level (16). In islets of *ob/ob* mice obtained from the Jackson Laboratories (an inbred colony), RY_2 message was not detected even on PCR amplification (18). Thus,

the level of RY receptors in different strains of *ob/ob* mice varies. This may be one reason why caffeine and ryanodine are either not effective (21) or only marginally effective (20) in *ob/ob* β -cells. One study compared the levels of IP_3Rs and RY receptors in mouse islets and concluded that mouse islets contain only RY_2 and almost no IP_3Rs . However, these authors did not use efficient primers for $\text{IP}_3\text{R-1}$, as they did not detect $\text{IP}_3\text{R-1}$ mRNA in the brain (18).

The relative densities of RY receptors and IP_3Rs in β -cells may vary in different species. However, evidence that human β -cells have RY receptors is convincing (19). Finally, it must be remembered that there is often no direct relationship between channel densities and the magnitude of a functional response. Thus, despite relatively low densities, strategic location of these channels at intracellular sites may be important for cell function.

STRUCTURES AND PROPERTIES OF RY RECEPTORS

Molecular make-up of RY receptors. RY receptors are made of four ~ 560 -kDa RY receptor protomers and four associated molecules of FKBP12 or FKBP12.6 (31). The latter are isoforms of the 12-kDa binding protein for the drug FK506. Each subunit of the RY receptor may form a pore and FKBP enables the four subunits to gate as one unit. The channel is a macromolecular complex with >20 associated proteins including calmodulin, calsequestrin, anchoring proteins, kinases, and phosphatases. The subunits of RY receptor have an enormous NH_2 -terminal cytosolic domain followed by 4–10 highly conserved transmembrane segments, which are followed by another short cytosolic domain. Cryoelectron microscopy and 3D-reconstruction reveal that RY receptor is a fourfold symmetrical mushroom-like structure with a large cytosolic assembly and a short transmembrane region. The cytosolic domain is the modulatory region and contains binding sites for Ca^{2+} , adenine nucleotides, calmodulin, FKBP as well as the phosphorylation sites.

FK506-binding protein and RY receptor. FKBP12.6 binds to isoleucine-proline sequence of each subunit of RY_2 receptors and thereby stabilizes the RY receptor tetramer and facilitates coordinated gating of the channel. Immunosuppressants used in islet transplantation, e.g., sirolimus (rapamycin) and tacrolimus (FK506), bind to FKBP12.6. Islets contain FKBP12.6 and FK506 releases Ca^{2+} from islet microsomes. According to one report, cADPR activates RY receptor by binding to FKBP12.6, but this view is not supported by other studies (32,33).

Basic molecular properties of RY receptors. RY receptor is a cation-selective channel that allows permeation of Ca^{2+} , many other divalent and monovalent cations, and under certain experimental conditions, even large molecules like glucose (34). Because of its short and wide channel region, RY receptor is suitable for sudden and large release of Ca^{2+} from intracellular stores. Ca^{2+} conductance of RY receptor is on the order of 100 pS, which compares to about 10 pS for voltage-gated Ca^{2+} channels. Physiological regulators of RY receptors include Ca^{2+} , Mg^{2+} , and ATP, which act by binding to the cytosolic sites. An important property of RY receptors is that they are regulated by ER Ca^{2+} load: the open probability of RY receptor is reduced as the luminal $[\text{Ca}^{2+}]$ is reduced. Ca^{2+}

may be released spontaneously and cyclically when the ER Ca^{2+} load is high (35–37).

Ca^{2+} -induced Ca^{2+} release. A fundamental property of RY receptors is that they can be both activated and inhibited by cytosolic Ca^{2+} . Ca^{2+} at nanomolar to micromolar concentration increases the open probability of RY₂ receptor by acting on the high-affinity Ca^{2+} -binding sites. The concentration and speed of delivery of Ca^{2+} are critical determinants for activation of RY receptors (35). Activation of L-type Ca^{2+} channels at more negative potentials (e.g. -40 to -10) is more effective in activating RY receptor because of larger driving force of Ca^{2+} at more negative voltages. Brief opening of L-type Ca^{2+} channels may be more effective in activating RY receptors than long-lasting opening. A micromolar to millimolar concentration of Ca^{2+} decreases open probability of RY receptor by acting on the low-affinity Ca^{2+} -binding sites. Mg^{2+} competes with Ca^{2+} at both the activation and inhibition sites of RY receptors.

RY receptor and redox states. The tetrameric RY₂ has ~80 free cysteines, some of which are critical for gating the channel. Reduced glutathione inhibits, and oxidized glutathione activates RY receptors (38). Redox-active molecules including NO and free radicals may thus affect RY receptors, and such processes are likely to be of physiological or pathological significance. Thiol oxidation has been shown to activate β -cell RY receptor (5), leading to release of Ca^{2+} from intracellular stores and increase of $[\text{Ca}^{2+}]_c$ (39).

RY RECEPTOR PHARMACOLOGY

RY receptors have binding sites for many agents reflected in the huge size of these channels. Methylxanthines, imidazoles and imidazolines, perchlorates, suramin, and volatile anesthetics activate RY receptor. Inhibitors of RY receptors include ruthenium red, procaine, tetracaine, ryanodine, dantrolene, and octanol. Some of these agents have additional concentration-dependent effects on other channels or pumps. On the other hand, drugs such as verapamil and D600, commonly used as blockers of L-type Ca^{2+} channel, also inhibit RY receptors (40). Familiarity with the usage and mechanism of action of these pharmacological tools is important for RY receptor studies.

Ca^{2+} release by methylxanthines, imidazoles, and imidazolines. Millimolar concentrations of methylxanthines activate RY receptors directly and may increase cAMP level indirectly, i.e., by inhibiting phosphodiesterases (PDEs). Caffeine is the most commonly used RY receptor-activator in muscle and neuronal research. The methylxanthines extensively used in islet research are theophylline and 3-isobutyl-1-methylxanthine (IBMX). The effects of theophylline and caffeine as activators of RY receptors are highly comparable (41). Millimolar concentrations of IBMX, commonly used as a PDE inhibitor, can activate RY receptors directly (42). In this respect, the efficacies of 1.5 mmol/l caffeine, theophylline, and IBMX may be almost equal (43).

Many imidazoles and imidazolines activate RY receptors (44). The imidazole ring is part of the xanthine structures and appears to be necessary for activating RY receptors (45). cAMP has an imidazole moiety as part of its structure. Dibutyryl cAMP, a lipophilic analog of cAMP, when

used at millimolar concentration can activate RY receptor directly by binding to the caffeine site (44). Theophylline, IBMX, and imidazole release Ca^{2+} from intracellular stores of β -cells (10,46–48). Ca^{2+} release from ER stores can be detected by measuring Ca^{2+} -activated plasma membrane conductance. In glucose-primed islets, theophylline increases $^{86}\text{Rb}^+$ efflux (49,50) and hyperpolarizes the β -cell membrane (50), suggesting Ca^{2+} release from the ER and consequent activation of calcium-activated K^+ channels (K^+_{ca}). This Ca^{2+} release and consequent increased $^{86}\text{Rb}^+$ efflux cannot be entirely due to inhibition of PDEs. The structurally related activator of RY receptors, imidazole, which activates PDEs (51,52), also increases $^{86}\text{Rb}^+$ efflux (indicating Ca^{2+} release from ER) in glucose-primed islets (53).

Ca^{2+} release by caffeine. Compared with theophylline and IBMX, fewer studies tested Ca^{2+} release by caffeine in β -cells. The main regulator of RY₂ receptor is Ca^{2+} , which activates or inhibits the channel, depending on concentration of the ion and the rate at which it is delivered. Ca^{2+} binds to separate high-affinity activation and low-affinity inhibition sites on the RY receptor. There is thus a competition between the two, and it appears that activation can only take place if the increase in $[\text{Ca}^{2+}]_c$ is fast (35,54). The full-blown Ca^{2+} release by caffeine, as occurs in situ is a two-step process; in the first step, there is a small Ca^{2+} release by caffeine. If the released Ca^{2+} is mopped up, for instance, by binding to high intracellular buffers or fura-2, the second step will not be engaged (54). The second step is a regenerative phenomenon in which released Ca^{2+} acts on a cluster of RY receptors, triggering large Ca^{2+} release. Caffeine increases the Ca^{2+} affinity of the Ca^{2+} activation site of RY receptor. For caffeine to activate RY receptor optimally, it must increase the sensitivity of the activation site to Ca^{2+} quickly, so that there is little time for inhibition of the channel by the released Ca^{2+} (54). Slow application of caffeine by conventional perfusion systems driven by peristaltic pumps may not elicit a rise in $[\text{Ca}^{2+}]_c$ (20). Furthermore, when channel density is low, a modest Ca^{2+} release by caffeine is counteracted by extrusion and uptake mechanisms (55). Caffeine applied rapidly by a puffer pipette or a U-tube (56) typically induces transient increase in $[\text{Ca}^{2+}]_c$ (16,19, 29,57–59). Dose-response studies of Ca^{2+} release by caffeine in β -cells have not been reported but the most commonly used concentration is 5–10 mmol/l. From studies in other cells, it is known that the threshold concentration of caffeine for Ca^{2+} release is ~250 $\mu\text{mol/l}$ (43).

When $[\text{Ca}^{2+}]_c$ is measured in single β -cells, only ~20–50% of cells respond to caffeine (16,17,58). This suggests that several conditions must be fulfilled for activation of RY receptors. The number of cells responding to caffeine and magnitude of Ca^{2+} release is increased by various maneuvers. Adequate Ca^{2+} loading of the ER, slightly elevated basal $[\text{Ca}^{2+}]_c$, low cytosolic $[\text{Mg}^{2+}]$, and synchronous activation of many RY receptors seem to be necessary to elicit a Ca^{2+} transient with caffeine. Experimentally, the Ca^{2+} pools can be filled, for instance, by depolarizing the cell transiently, allowing Ca^{2+} entry through the voltage-gated Ca^{2+} channels, before applying caffeine (19,54). The number of excitable RY receptors can be increased by protein kinase A (PKA) phosphorylation (16,60). Cytosolic $[\text{Mg}^{2+}]$ can be

reduced by increasing intracellular [ATP], for instance, by providing high glucose.

A difficulty in interpreting Ca^{2+} data obtained with caffeine arises from the fact that the xanthine drug inhibits PDEs. Furthermore, caffeine and theophylline can cause modest depolarization of β -cell plasma membrane (20) by inhibiting K_{ATP} (ATP-sensitive potassium) channel and possibly by activating a nonselective cation channel in the plasma membrane (61). The resulting Ca^{2+} entry through the plasma membrane Ca^{2+} channels may obscure caffeine-induced Ca^{2+} release (20). Experimentally such difficulties can be avoided if caffeine is used under conditions in which membrane potential is clamped at -70 mV (19).

Other activators of RY receptors. 9-methyl-7-bromoedistomin D is a novel activator of RY receptors (62). It is useful since it is not a methylxanthine and does not inhibit PDEs. 4-chloro-*m*-cresol and 4-chloro-3-ethylphenol are also useful since they do not inhibit PDEs, activate RY receptors, and do not activate IP_3Rs (16,22,63,64). However, they inhibit islet metabolism (65).

Effect of ryanodine on RY receptor. The molecular basis of ryanodine action is still poorly understood. RY receptors have a single high-affinity site and a separate low-affinity site for ryanodine. The alkaloid can both activate and inhibit RY receptor, making it sometimes difficult to interpret the results obtained with ryanodine. In general, nanomolar ryanodine sensitizes RY receptor to activation by Ca^{2+} and micromolar ryanodine inhibits it. Some analogs of ryanodine (e.g., β alanyl ryanodine) only activate the channel, but we have not found them useful in experiments with intact β -cells (16). In cell-free systems, prolonged exposure to a high concentration of ryanodine (e.g., $10 \mu\text{mol/l}$) locks the RY receptor in a partially open state. Such treatment eventually depletes the ryanodine-sensitive Ca^{2+} pools because of drainage of Ca^{2+} . Very high concentrations of ryanodine (e.g., $100 \mu\text{mol/l}$ to 10mmol/l) completely block the channel. Inhibition of cellular processes by high concentrations of ryanodine is taken as evidence for the involvement of RY receptors. However, ryanodine binding is use-dependent; the alkaloid binds only to the open conformation of the channel. For demonstrating inhibition by ryanodine, the RY channel must first be opened in the presence of the alkaloid and maintained open for a long time to allow ryanodine-binding to the inhibitory binding sites. Thus, when cells are pretreated in the presence of caffeine (or elevated $[\text{Ca}^{2+}]_c$) and ryanodine for 5–30 min, the RY receptor of RINm5F cells (24) and β -cells is inhibited (19). If such protocols are not used and ryanodine is added to the perfusion for a brief period, the RY receptor of β -cells may appear to be insensitive to the inhibitory action of the alkaloid (59,64). This may explain why some reports demonstrate clear effect of ryanodine on β -cells (19,66,67), whereas others find little or no effect (2,3). It must be emphasized that it is often difficult to inhibit RY receptors by high concentration of ryanodine in intact cells and such lack of inhibition alone should not preclude conclusions as to the existence or involvement of RY receptors in intact cells (68).

REGULATION OF RY RECEPTORS BY SECOND MESSENGERS

PKA-dependent and -independent effect of cAMP on CICR. cAMP is not primarily a Ca^{2+} -releasing messenger

in the sense that inositol 1,4,5-trisphosphate *per se* does not release Ca^{2+} from ER of β -cells when the $[\text{Ca}^{2+}]_c$ or ER luminal $[\text{Ca}^{2+}]$ is low (16). cAMP, through PKA-mediated phosphorylation, ensures the *in situ* excitability of RY receptor. In resting β -cells, $[\text{Ca}^{2+}]_c$ is low and cytosolic $[\text{Mg}^{2+}]$ is high, which keeps the RY receptors inhibited. cAMP-dependent phosphorylation *per se* does not activate the channel; instead it releases the channel from Mg^{2+} inhibition (60). PKA phosphorylation brings the RY_2 receptor to an excitable state: the channel can then be excited either by the Ca^{2+} entering through the voltage-gated Ca^{2+} channels or simply by high loading of the ER (37). Furthermore, PKA phosphorylation favors dissociation of FKBP12.6 from RY_2 and thus increases open probability of the channel (31).

Kang et al. (26) have described a PKA-independent effect of cAMP on the RY receptor of β -cells. In this mode, cAMP promotes Ca^{2+} release through RY receptor as a consequence of increased filling of the ER by a mechanism that involves cAMP-regulated guanine nucleotide exchange factor and its interaction with Rap1b (26,69). There is no consensus as to the consequences of phosphorylation of IP_3Rs in terms of Ca^{2+} release. Xestospongic C, an inhibitor of IP_3Rs , does not inhibit CICR in β -cells, suggesting that IP_3Rs do not play a major role in mediating CICR in these cells (26). Some reports indicate that phosphorylation of type 1 and type 3 IP_3Rs decreases Ca^{2+} release (70,71). Detailed studies in β -cells suggest that, when cAMP releases Ca^{2+} from ER, it is likely that the release is through RY receptor rather than through IP_3Rs (19,72).

Modulation of RY receptors by nitric oxide. In β -cells, nitric oxide (NO) releases Ca^{2+} from ER (17,73). There is evidence that this is due to activation of the RY receptors (17). NO reversibly activates RY receptors by oxidation or by poly-S-nitrosylation (74) of critical thiols associated with the channel (5,39,75). The effects of NO (and cGMP-mediated phosphorylation) on IP_3Rs are largely inhibitory (76). Another pathway by which NO activates RY receptor is via cGMP, which in turn activates ADP-ribosyl cyclase, leading to formation of cADPR (77). This pathway is not involved in NO-induced Ca^{2+} release in β -cells since specific inhibitors of cADPR do not block this release (57). NO induced Ca^{2+} release in β -cells has been implicated in exocytosis (17), synchronization of Ca^{2+} signal (73), and apoptosis (78).

Cyclic ADP-ribose. The NAD^+ metabolite cADPR releases Ca^{2+} through a RY receptor-like channel (79). cADPR, however, does not bind to RY receptor or FKBP associated with the channel (32), and some investigators do not see any effect of cADPR on RY receptors (33). In β -cells, cADPR releases Ca^{2+} from the ER (18), but this has not been a universal finding (12,80,81). Inappropriate experimental conditions as well as low levels of RY receptors in some insulin-secreting cells may partly account for such differences. More recently, Mitchell et al. (22) and Varadi and Rutter (82) used techniques that are sensitive in detecting local Ca^{2+} release from secretory vesicles and ER. Their data provide convincing evidence that micromolar cADPR releases Ca^{2+} from both the secretory vesicles and ER of MIN6 cells. It is not clear whether this is due to specific interaction of cADPR with

its channel or due to interaction of cADPR with the adenine-nucleotide binding site of the RY receptors (83). In this regard, information on whether Ca^{2+} release by cADPR could be inhibited by inhibitors, e.g., 7-deaza-8-bromo-cyclic ADP-ribose, would be useful. It is noteworthy that cADPR antagonists cannot inhibit Ca^{2+} release through RY receptors of β -cells, suggesting that cADPR receptor may be different from RY receptors (57). Nevertheless, these recent data, together with the fact that glucose increases cADPR in β -cells, should renew interest in search for the elusive cADPR receptor (18,84).

REGULATION OF RY RECEPTORS BY SIGNALS GENERATED FROM GLUCOSE METABOLISM

β -cells act as fuel sensors by virtue of having K_{ATP} channels (85). However, the cells continue this function even under conditions in which K_{ATP} channels are clamped by diazoxide (86). It is likely that ATP and some other molecules arising from nutrient metabolism act on other ion channels or exocytotic processes. Molecules that arise from nutrient metabolism and activate RY receptors include ATP, glycolytic intermediates, palmitoyl CoA, and cADPR. Moreover, a physiological alkaline shift of intracellular pH, such as that occurs on glucose stimulation, favors activation of the RY receptor (87). In *in vitro* experiments, it is possible to demonstrate that glucose releases Ca^{2+} from the ER, suggesting that some metabolites of glucose may favor activation of intracellular Ca^{2+} channels (88).

ATP. ATP favors Ca^{2+} release through RY receptors by 1) filling the Ca^{2+} stores, 2) binding Mg^{2+} and thereby reducing cytosolic $[Mg^{2+}]$, and 3) allosteric regulation of RY receptor. In the presence of subactivating $[Ca^{2+}]$, physiological levels of ATP directly activates RY_2 receptor by acting on the ATP-binding site, whereas ADP acts as a partial agonist (89). In resting β -cells, high cytosolic $[Mg^{2+}]$ keeps the RY receptor inhibited. Glucose stimulation reduces cytosolic $[Mg^{2+}]$ by increasing ATP production and $[ATP]$ (90) and thereby facilitates RY receptor activation.

Glycolytic intermediates. Fructose 1,6-diphosphate (FDP), a product of the rate-limiting enzyme phosphofructokinase, activates RY_2 receptor and sensitizes the receptor to other activators (91,92). Consistent with this, FDP stimulates insulin secretion from HIT-T15 cells (27,93). It should be noted that FDP and several other glycolytic intermediates inhibit binding of IP_3 to IP_3 Rs, thus making it unlikely that IP_3 Rs participate in this response (92).

Long-chain acyl CoA. Glucose metabolism increases level of cytosolic long-chain acyl CoA (94). Such long-chain acyl CoAs sensitize RY_2 receptors of β -cells (22). Palmitoyl CoA sensitizes RY_2 receptors to activation by Ca^{2+} by mechanisms that include relief of Mg^{2+} inhibition of the channel.

cADPR. Several groups have demonstrated acute increase of cADPR in glucose-stimulated β -cells (84,95), but this is not a universal observation (96). Measurement of cADPR in β -cells seems to be technically difficult. Recent availability of a more convenient and sensitive method for cADPR measurement may be helpful in elucidating the signaling role of cADPR in β -cells (97).

ROLE OF RY RECEPTORS IN MITOCHONDRIAL Ca^{2+} SIGNALING

Mitochondrial ATP production is essential for stimulus-secretion coupling in β -cells. An increase in $[Ca^{2+}]_c$ increases mitochondrial Ca^{2+} concentration ($[Ca^{2+}]_m$) and enhances mitochondrial ATP production (98). Because ER and mitochondria appear to be in close opposition, some RY receptors may be located close to the mitochondria. Studies in many cells have demonstrated a functional coupling between RY receptors and mitochondria. In β -cells, an important function of RY receptors may be to amplify Ca^{2+} signals by CICR to produce microdomains of high $[Ca^{2+}]_c$, which would act as sources for elevating $[Ca^{2+}]_m$ and thus accelerate ATP production.

ROLE OF RY RECEPTORS IN GLUCOSE-STIMULATED INSULIN SECRETION

The effects of Ca^{2+} on cellular processes depend on the subcellular location of the $[Ca^{2+}]_c$ increase. Furthermore, the integrity of the $[Ca^{2+}]_c$ oscillatory process is important for secretion. Ca^{2+} release through RY receptor may affect secretion positively or negatively. By increasing $[Ca^{2+}]_c$ near the secretory sites, it may trigger exocytotic fusion of the secretory granules with the plasma membrane. On the other hand, by increasing $[Ca^{2+}]_c$ near K^+_{Ca} channels, it can result in hyperpolarization of the β -cell membrane and inhibit secretion. Intermittent release of Ca^{2+} through RY receptor will have an intermittent hyperpolarizing effect, which may not inhibit net secretion and may rather increase it. Persistent release of Ca^{2+} will hyperpolarize for a prolonged period and will lead to inhibition of secretion. Whether Ca^{2+} released through RY receptor is more readily available to the exocytotic sites or to the site of K^+_{Ca} channels is not known. In adrenal chromaffin cells, Ca^{2+} released through RY receptors is predominantly for driving the exocytotic processes (29,99). In β -cells, Ca^{2+} released through the RY receptors appear to be available to the exocytotic sites for stimulating secretion (17).

The role of RY receptors can be examined by testing the effects of methylxanthines. Because these tools have side effects, results need to be interpreted with careful reflection. By sensitizing RY receptors to incoming Ca^{2+} , methylxanthines enhance CICR. By this means and the consequent effect on K^+_{Ca} channels, methylxanthines are expected to terminate a burst earlier and to shorten the duration of the slow waves. By affecting another group of K^+ channels, i.e., inhibiting the K_{ATP} channels directly, methylxanthines shorten the interval between the slow waves. The net effect is an increase in the number of bursts per minute. Such effects on electrical activity of β -cells are seen when theophylline is applied to β -cells stimulated by glucose (50,100). Consistent with this, theophylline and caffeine markedly potentiate glucose-induced insulin secretion (101,102). At high concentrations, caffeine inhibits glucose transport (103) but still stimulates insulin secretion (20,104,105). Stimulation of insulin secretion by caffeine and theophylline is tacitly assumed to be solely due to cAMP. However, an examination of the quantitative aspects of secretion by theophylline and cAMP suggests involvement of RY receptors. Thus, in rat islets, in Ca^{2+} -free medium and 16.7 mmol/l glucose, 1.4 mmol/l theophylline stimulates insulin secretion, which is

three times more than that induced by 1 mmol/l dibutyryl cAMP (106). Imidazole, which does not inhibit islet PDEs (51), but sensitizes RY receptors (44), stimulates secretion (107). Another way to dissect the RY receptor-activating and the PDE-inhibitory effect of methylxanthines is to use RY receptor inhibitors. In rat islets, tetracaine inhibits insulin secretion stimulated by theophylline (106). It should be emphasized that RY₂ receptor can be sensitized by cAMP-dependent phosphorylation (60) as well as by direct binding of methylxanthines to the channel. In either case, the main trigger for activation of RY receptor is still the Ca²⁺ that enters through the voltage-gated Ca²⁺ channels. Thus, despite reservations about nonspecific actions of these drugs, the available data strongly support a role for RY receptors in glucose-induced exocytosis of insulin.

There is now compelling evidence that cAMP-linked incretin hormones stimulate glucose-dependent insulin secretion by mechanisms that include CICR through RY receptors (19,26,66). Secretion is a complex process requiring more than just an elevation of [Ca²⁺]_c. Since Ca²⁺ released through RY receptor is available to both exocytotic sites and the K⁺_{ca} channel sites, it is not surprising that both stimulation and inhibition of secretion have been reported with RY receptor ligands. The results depend on the experimental conditions used and it is often so that the experimental protocols employed do not mimic the physiological situation. Thus NO, which activates RY receptor, can stimulate (108) or inhibit (109) insulin secretion. Imidazole, an activator of RY receptors can stimulate (107) or inhibit (110) secretion. Dantrolene, an inhibitor of RY receptor, has also been shown to inhibit (111) or stimulate (112) glucose-induced insulin secretion.

PHYSIOLOGICAL ROLES OF RY RECEPTORS IN GLUCOSE-INDUCED STIMULUS-SECRETION COUPLING

Depolarization-induced [Ca²⁺]_c increase in β-cells is not just due to Ca²⁺ entry through the voltage-gated Ca²⁺ channels. There is evidence that this Ca²⁺ signal is modulated by CICR and uptake of Ca²⁺ into ER (2,3). In patch clamp experiments, Ca²⁺ entry through voltage-gated Ca²⁺ channels may be overestimated. Most voltage clamp experiments in β-cells are done in the presence of very high extracellular [Ca²⁺]_e and a highly buffered and altered cytosolic environment. In such experiments, unlimited extracellular space permits a large influx of Ca²⁺ through the channel. The [Ca²⁺]_c increase obtained on depolarization in human β-cells is usually not very high (~300 nmol/l) (88). However, when conditions are created where incoming Ca²⁺ can trigger the RY receptors, a very large increase in [Ca²⁺]_c is seen (2,19,113). It is possible that under physiological conditions, there is relatively small Ca²⁺ entry through the voltage-gated Ca²⁺ channels, which in turn is amplified by CICR.

Even if one accepts that β-cells do not have large amounts of RY receptors, they may be important because of their large conductance and strategic location within the cell. Some RY receptors drain a nonmitochondrial Ca²⁺ pool that does not utilize a thapsigargin-sensitive pump (5). This Ca²⁺ pool may represent the secretory vesicles (22). RY receptors located on secretory vesicles (22,114) will allow a highly localized increase of [Ca²⁺]_c at exocytotic sites promoting exocytotic fusion. CICR may

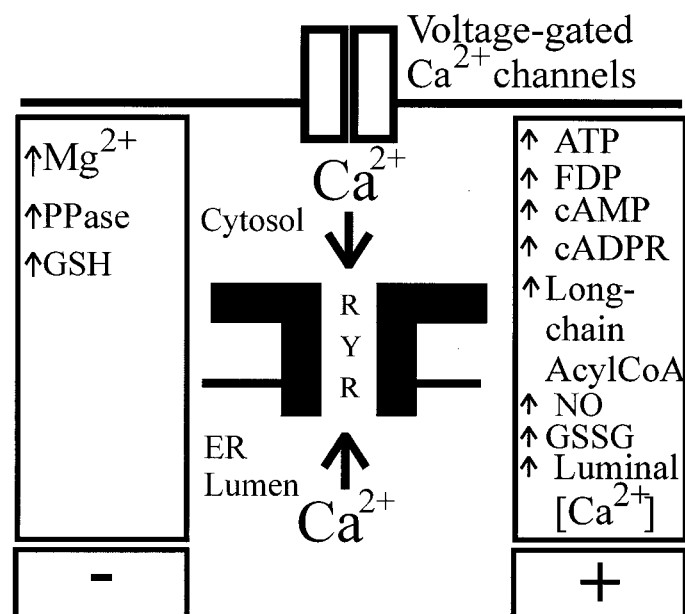

FIG. 1. In situ activation of RY receptor is viewed as a context-dependent phenomenon. Schematic diagram illustrating context-dependence of activation of RY receptors: Ca²⁺ is the main trigger for RY receptor activation. The concentration and speed of delivery of Ca²⁺ are critical determinants for activation of RY receptors. Activation of RY receptors by Ca²⁺ (or other agonists) is determined by the context provided by a large number of molecules and processes, some of which are listed here. An elevated level of molecules listed in the right box increases sensitivity of the RY receptor to activation. PKA phosphorylation and high luminal Ca²⁺ concentration favors RY receptor activation. cAMP can sensitize RY receptor also by PKA-independent mechanisms that promote filling of the ER pools. Mg²⁺ and phosphates reduce sensitivity of RY receptors. RY receptor can “spontaneously” release Ca²⁺ provided the context is right. RY receptor together with the ER-associated Ca²⁺ apparatus constitutes a functional unit that is able to integrate signals and respond by detecting co-incident signals.

allow brief bout of Ca²⁺ entry through voltage-gated Ca²⁺ channels to generate a wave of [Ca²⁺]_c changes, which is required in the early steps of exocytosis, e.g., vesicle transport to exocytotic sites (115).

Another myth that has been propagated over the years is that glucose alone is the most important stimulus for insulin secretion. In fact, in the physiological range of excursion of glucose concentration, glucose is a rather poor stimulator of insulin secretion from pure β-cells. This is because glucose per se is not very effective in engaging CICR, which can be engaged efficiently if the process is sensitized, for instance, by cAMP-linked hormones (116). It needs to be emphasized that CICR is a multistep process that is facilitated by many factors (2,26). RY receptors, together with the ER-associated Ca²⁺ apparatus, act as a functional unit for co-incident detection. A critical feature of RY receptor is that its gating is context-dependent (Fig. 1). Thus, optimal amplification of Ca²⁺ signaling occurs only when several conditions are simultaneously satisfied. Such factors include an ER full of Ca²⁺, elevated levels of FDP, cAMP, ATP, NO, low [Mg²⁺], alkaline pH, and others. The amplified Ca²⁺ signals often take the form of regenerative spike-like oscillations and presumably leads to very high local [Ca²⁺]_c. Many Ca²⁺-dependent processes, including exocytosis, require very high [Ca²⁺]_c, and CICR may be a molecular process to achieve this (117). The significance of this mode of signaling is illustrated by the fact that cAMP-linked incretin hormones,

e.g., GLP-1, utilizes this process to stimulate insulin secretion in a typical context-dependent manner.

STUDIES ON KNOCKOUT MICE

Knockout mice for each of the RY receptors have been generated. However RY_1 - and RY_2 -deficient mice die at embryonic stage or after birth. It may be useful to have mice in which RY receptors are knocked out specifically in the β -cells. Knockout of CD38, which catalyzes synthesis of cADPR, impairs glucose-induced formation of cADPR, elevation of $[\text{Ca}^{2+}]_c$, as well as insulin secretion (95).

RELEVANCE TO DIABETES

From studies in various animal models of type 2 diabetes, it appears that impairment of mechanisms that ensure optimal secretory response of β -cells is an important component in the pathogenesis of type 2 diabetes (118). Impaired function of intracellular Ca^{2+} pools of β -cells has been described in several rodent models of type 2 diabetes (4,119). From the evidence discussed above, it seems fair to speculate that RY receptor-mediated CICR may be one of the many mechanisms that normally amplify insulin secretion following a trigger by nutrients (86). Impaired glucose metabolism in β -cells will fail to trigger insulin secretion because of impaired ATP production. At the same time, such impairment may also impair CICR because of impaired production of molecules such as FDP, long-chain acyl CoA, cADPR, cAMP, etc.—molecules that normally sensitize the RY receptors. One of the mechanisms utilized by cAMP-linked incretin hormones to amplify insulin secretion is clearly the RY receptor-mediated CICR, and such hormones are potential antidiabetic drugs (19). RY receptor may be relevant to the pathogenesis of type 1 diabetes also since this channel is a prototypic redox-sensitive Ca^{2+} channel and may thus mediate damaging actions of NO and free radicals (78).

CONCLUSION

The existence of RY receptors in β -cells is well documented. Any controversies about RY receptors of β -cells, including those involving cADPR, may be intrinsic to the complex mode of regulation of these channels and difficulties associated with the usage of the pharmacological tools. One example of this is the distinct context-dependence of activation of RY receptors. Despite its low abundance, RY receptors of β -cells may play important roles in stimulus-secretion coupling by virtue of their strategic locations within the cell, their ability to mediate CICR in a context-dependent manner, and their large conductance. Being Ca^{2+} -activated ion channels, RY receptors have the unique ability to interact with neighboring Ca^{2+} channels and thereby amplify Ca^{2+} signals. Such amplification is engaged when the channel is sensitized by a set of messenger molecules generated from nutrient metabolism or ligand-binding. RY receptors are thus suitable for integration of signaling, co-incidence detection, and context-dependent signaling for insulin secretion. Secretagogues may modulate insulin secretion by affecting CICR mediated by RY receptor. Such processes may be involved in amplification of insulin secretion and may be a target for development of therapeutic agents that

may stimulate insulin secretion in a context-dependent manner.

Future directions. Explicit recognition of the fact that β -cells possess a robust mechanism for amplification of Ca^{2+} signaling may advance our understanding of stimulus-secretion coupling. Rigorous attention to experimental protocols, a clear understanding of the mechanism of action of RY receptor ligands as well as context-dependence of activation of these channels will help reduce controversies and move the field forward. Nevertheless, the issues involved need to be critically examined. In this respect, quantitative data on the relative densities of RY receptors and IP_3Rs and their relative contribution in Ca^{2+} signaling in β -cells, especially in human β -cells, will be helpful. β -cells may be heterogeneous in terms of the level of RY receptors and IP_3Rs . Hormonal and metabolic factors may alter RY receptor level in β -cells. The nature of coupling of voltage-gated Ca^{2+} channels to RY receptors, local exchange of signals between these channels, and their roles in local Ca^{2+} signaling need to be elucidated. Ca^{2+} release through IP_3Rs may also be a trigger for RY receptor-mediated CICR. In β -cells, this possibility is supported by the observation that dantrolene inhibits $[\text{Ca}^{2+}]_c$ response by cholinergic agonists in β -cells (88). Finally, the role of RY receptor-mediated CICR as a general mechanism for amplification of insulin secretion and factors that affect this process need to be explored.

ACKNOWLEDGMENTS

Financial support was obtained from the Juvenile Diabetes Research Foundation International, Swedish Medical Research Council (K2001-32X-13469-02B), The Swedish Council for Natural Science Research, Swedish Fund for Research Without Animal Experiments, and the Karolinska Institutet.

M.S.I. is a recipient of a career development award from the Juvenile Diabetes Research Foundation International.

The author is grateful to Drs. C. J. Barker, J. D. Bruton, and T. Nilmon for comments on the manuscript, and gratefully acknowledges anonymous reviewers for the useful comments.

REFERENCES

- Islam MS: Calcium and diabetes. In *Calcium: The Molecular Basis of Calcium Action in Biology and Medicine*. Pochet R, Donato R, Haiech J, Heizmann CW, Gerke V, Eds. Amsterdam, Kluwer Academic Publishers, 2000, p. 402–413
- Lemmens R, Larsson O, Berggren PO, Islam MS: Ca^{2+} -induced Ca^{2+} release from the endoplasmic reticulum amplifies the Ca^{2+} signal mediated by activation of voltage-gated L-type Ca^{2+} channels in pancreatic β -cells. *J Biol Chem* 276:9971–9977, 2001
- Gilon P, Arredouani A, Gailly P, Gromada J, Henquin JC: Uptake and release of Ca^{2+} by the endoplasmic reticulum contribute to the oscillations of the cytosolic Ca^{2+} concentration triggered by Ca^{2+} influx in the electrically excitable pancreatic B-cell. *J Biol Chem* 274:20197–20205, 1999
- Roe MW, Philipson LH, Frangakis CJ, Kuznetsov A, Mertz RJ, Lancaster ME, Spencer B, Worley JF, Dukes ID: Defective glucose-dependent endoplasmic reticulum Ca^{2+} sequestration in diabetic mouse islets of Langerhans. *J Biol Chem* 269:18279–18282, 1994
- Islam MS, Rorsman P, Berggren PO: Ca^{2+} -induced Ca^{2+} release in insulin-secreting cells. *FEBS Lett* 296:287–291, 1992
- Hagar RE, Ehrlich BE: Regulation of the type III InsP_3 receptor and its role in β cell function. *Cell Mol Life Sci* 57:1938–1949, 2000
- Oyamada H, Murayama T, Takagi T, Iino M, Iwabe N, Miyata T, Ogawa Y, Endo M: Primary structure and distribution of ryanodine-binding protein

- isoforms of the bullfrog skeletal muscle. *J Biol Chem* 269:17206–17214, 1994
8. Tunwell REA, Wickenden C, Bertrand BM, Shevchenko VI, Walsh MB, Allen PD, Lai FA: The human cardiac muscle ryanodine receptor-calcium release channel: identification, primary structure and topological analysis. *Biochem J* 318:477–487, 1996
 9. Saier MH, Jr, Eng BH, Fard S, Garg J, Haggerty DA, Hutchinson WJ, Jack DL, Lai EC, Liu HJ, Nusinew DP, Omar AM, Pao SS, Paulsen IT, Quan JA, Sliwinski M, Tseng TT, Wachi S, Young GB: Phylogenetic characterization of novel transport protein families revealed by genome analyses. *Biochim Biophys Acta* 1422:1–56, 1999
 10. Malaisse WJ: Theophylline-induced translocation of calcium in the pancreatic β cell: inhibition by deuterium oxide. *Nat New Biol* 242:189–190, 1973
 11. Prentki M, Biden TJ, Janjic D, Irvine RF, Berridge MJ, Wollheim CB: Rapid mobilization of Ca^{2+} from rat insulinoma microsomes by inositol-1,4,5-trisphosphate. *Nature* 309:562–564, 1984
 12. Islam MS, Larsson O, Berggren PO: Cyclic ADP-ribose in β cells. *Science* 262:584–586, 1993
 13. Blondel O, Takeda J, Janssen H, Seino S, Bell GI: Sequence and functional characterization of a third inositol trisphosphate receptor subtype, IP3R-3, expressed in pancreatic islets, kidney, gastrointestinal tract, and other tissues. *J Biol Chem* 268:11356–11363, 1993
 14. Missiaen L, Parys JB, Sienart I, Maes K, Kunzelmann K, Takahashi M, Tanzawa K, De Smedt H: Functional properties of the type-3 InsP3 receptor in 16HBE140-bronchial mucosal cells. *J Biol Chem* 273:8983–8986, 1998
 15. Takasawa S, Nata K, Yonekura H, Okamoto H: Cyclic ADP-ribose in insulin secretion from pancreatic β cells. *Science* 259:370–373, 1993
 16. Islam MS, Leibiger I, Leibiger B, Rossi D, Sorrentino V, Ekström TJ, Westerblad H, Andrade FH, Berggren PO: In situ activation of the type 2 ryanodine receptor in pancreatic β cells requires cAMP-dependent phosphorylation. *Proc Natl Acad Sci U S A* 95:6145–6150, 1998
 17. Willmott NJ, Galione A, Smith PA: Nitric oxide induces intracellular Ca^{2+} mobilization and increases secretion of incorporated 5-hydroxytryptamine in rat pancreatic β -cells. *FEBS Lett* 371:99–104, 1995
 18. Takasawa S, Akiyama T, Nata K, Kuroki M, Tohgo A, Noguchi N, Kobayashi S, Kato I, Katada T, Okamoto H: Cyclic ADP-ribose and inositol 1,4,5-trisphosphate as alternate second messengers for intracellular Ca^{2+} mobilization in normal and diabetic β -cells. *J Biol Chem* 273:2497–2500, 1998
 19. Holz GG, Leech CA, Heller RS, Castonguay M, Habener JF: cAMP-dependent mobilization of intracellular Ca^{2+} stores by activation of ryanodine receptors in pancreatic β -cells: a Ca^{2+} signaling system stimulated by the insulinotropic hormone glucagon-like peptide-1-(7-37). *J Biol Chem* 274:14147–14156, 1999
 20. Islam MS, Larsson O, Nilsson T, Berggren PO: Effects of caffeine on cytoplasmic free Ca^{2+} concentration in pancreatic β -cells are mediated by interaction with ATP-sensitive K^{+} channels and L-type voltage-gated Ca^{2+} channels but not the ryanodine receptor. *Biochem J* 306:679–686, 1995
 21. Tengholm A, Hellman B, Gylfe E: Mobilization of Ca^{2+} stores in individual pancreatic β -cells permeabilized or not with digitonin or alpha-toxin. *Cell Calcium* 27:43–51, 2000
 22. Mitchell KJ, Pinton P, Varadi A, Tacchetti C, Ainscow EK, Pozzan T, Rizzuto R, Rutter GA: Dense core vesicles revealed as a dynamic Ca^{2+} store in neuroendocrine cells with a vesicle associated membrane protein aequorin chimera. *J Cell Biol* 155:41–51, 2001
 23. Rutter GA, Theler JM, Li G, Wollheim CB: Ca^{2+} stores in insulin-secreting cells: lack of effect of cADP ribose. *Cell Calcium* 16:71–80, 1994
 24. Chen TH, Lee B, Yang C, Hsu WH: Effects of caffeine on intracellular calcium release and calcium influx in a clonal β -cell line RINm5F. *Life Sci* 58:983–990, 1996
 25. Gamberucci A, Fulceri R, Pralong W, Banhegyi G, Marcolongo P, Watkins SL, Benedetti A: Caffeine releases a glucose-primed endoplasmic reticulum Ca^{2+} pool in the insulin secreting cell line INS-1. *FEBS Lett* 446:309–312, 1999
 26. Kang G, Chepurmy OG, Holz GG: cAMP-regulated guanine nucleotide exchange factor II (Epac2) mediates Ca^{2+} -induced Ca^{2+} release in INS-1 pancreatic β -cells. *J Physiol* 536:375–385, 2001
 27. Taniguchi T, Yamada Y, Yasuda K, Kubota A, Ihara Y, Kagimoto S, Kuroe A, Watanabe R, Inada A, Seino Y: Expression of ryanodine receptors in a hamster pancreatic β cell-derived cell line (HIT-T15). *Endocrinol Metabol* 3:135–138, 1996
 28. Leite MF, Dranoff JA, Gao L, Nathanson MH: Expression and subcellular localization of the ryanodine receptor in rat pancreatic acinar cells. *Biochem J* 337:305–309, 1999
 29. von Ruden L, Neher E: A Ca-dependent early step in the release of catecholamines from adrenal chromaffin cells. *Science* 262:1061–1065, 1993
 30. Bennett DL, Cheek TR, Berridge MJ, De SH, Parys JB, Missiaen L, Bootman MD: Expression and function of ryanodine receptors in nonexcitable cells. *J Biol Chem* 271:6356–6362, 1996
 31. Marx SO, Reiken S, Hisamatsu Y, Jayaraman T, Burkhoff D, rosemblit n, Marks AR: PKA phosphorylation dissociates FKBP12.6 from the calcium release channel (ryanodine receptor): defective regulation in failing hearts. *Cell* 101:365–376, 2000
 32. Thomas JM, Masgrau R, Churchill GC, Galione A: Pharmacological characterization of the putative cADP-ribose receptor. *Biochem J* 359:451–457, 2001
 33. Copello JA, Qi Y, Jeyakumar LH, Ogunbunmi E, Fleischer S: Lack of effect of cADP-ribose and NAADP on the activity of skeletal muscle and heart ryanodine receptors. *Cell Calcium* 30:269–284, 2001
 34. Meissner G: Ryanodine activation and inhibition of the Ca^{2+} release channel of sarcoplasmic reticulum. *J Biol Chem* 261:6300–6306, 1986
 35. Fabiato A: Time and calcium dependence of activation and inactivation of calcium-induced release of calcium from the sarcoplasmic reticulum of a skinned canine cardiac Purkinje cell. *J Gen Physiol* 85:247–289, 1985
 36. Sitsapesan R, Williams AJ: Regulation of current flow through ryanodine receptors by luminal Ca^{2+} . *J Membr Biol* 159:179–185, 1997
 37. Fabiato A: Two kinds of calcium-induced release of calcium from the sarcoplasmic reticulum of skinned cardiac cells. *Adv Exp Med Biol* 311:245–262, 1992
 38. Zable AC, Favero TG, Abramson JJ: Glutathione modulates ryanodine receptor from skeletal muscle sarcoplasmic reticulum: evidence for redox regulation of the Ca^{2+} release mechanism. *J Biol Chem* 272:7069–7077, 1997
 39. Islam MS, Kindmark H, Larsson O, Berggren PO: Thiol oxidation by 2,2'-dithiodipyridine causes a reversible increase in cytoplasmic free Ca^{2+} concentration in pancreatic β -cells: role for inositol 1,4,5-trisphosphate-sensitive Ca^{2+} stores. *Biochem J* 321:347–354, 1997
 40. Valdivia HH, Valdivia C, Ma J, Coronado R: Direct binding of verapamil to the ryanodine receptor channel of sarcoplasmic reticulum. *Biophys J* 58:471–481, 1990
 41. Johnson PN, Inesi G: The effect of methylxanthines and local anesthetics on fragmented sarcoplasmic reticulum. *J Pharmacol Exp Ther* 169:308–314, 1969
 42. Usachev Y, Verkhratsky A: IBMX induces calcium release from intracellular stores in rat sensory neurones. *Cell Calcium* 17:197–206, 1995
 43. Liu W, Meissner G: Structure-activity relationship of xanthines and skeletal muscle ryanodine receptor/ Ca^{2+} release channel. *Pharmacology* 54:135–143, 1997
 44. Chapman RA, Miller DJ: Structure-activity relations for caffeine: a comparative study of the inotropic effects of the methylxanthines, imidazoles and related compounds on the frog's heart. *J Physiol* 242:615–634, 1974
 45. Rousseau E, Ladine J, Liu QY, Meissner G: Activation of the Ca^{2+} release channel of skeletal muscle sarcoplasmic reticulum by caffeine and related compounds. *Arch Biochem Biophys* 267:75–86, 1988
 46. Sehlin J: Calcium uptake by subcellular fractions of pancreatic islets. Effects of nucleotides and theophylline. *Biochem J* 156:63–69, 1976
 47. Gylfe E, Hellman B: Calcium and pancreatic β -cell function: modification of ^{45}Ca fluxes by methylxanthines and dibutyl cyclic-AMP. *Biochem Med* 26:365–376, 1981
 48. Siegel EG, Wollheim CB, Kikuchi M, Renold AE, Sharp GW: Dependency of cyclic AMP-induced insulin release on intra- and extracellular calcium in rat islets of Langerhans. *J Clin Invest* 65:233–241, 1980
 49. Carpinelli AR, Malaisse WJ: Regulation of ^{86}Rb outflow from pancreatic islets: the dual effect of nutrient secretagogues. *J Physiol* 315:143–156, 1981
 50. Henquin JC, Meissner HP: Effects of theophylline and dibutyl cyclic adenosine monophosphate on the membrane potential of mouse pancreatic β -cells. *J Physiol* 351:595–612, 1984
 51. Sams DJ, Montague W: The role of adenosine 3':5'-cyclic monophosphate in the regulation of insulin release: properties of islet-cell adenosine 3':5'-cyclic monophosphate phosphodiesterase. *Biochem J* 129:945–952, 1972
 52. Butcher RW, Sutherland EW: Adenosine 3,5-phosphate in biological materials. *J Biol Chem* 237:1244–1250, 1962
 53. Henquin JC: Metabolic control of the potassium permeability in pancreatic islet cells. *Biochem J* 186:541–550, 1980
 54. Hernandez-Cruz A, Escobar AL, Jimenez N: Ca^{2+} -induced Ca^{2+} release

- phenomena in mammalian sympathetic neurons are critically dependent on the rate of rise of trigger Ca²⁺. *J Gen Physiol* 109:147–167, 1997
55. Herchuelz A, Lebrun P: A role for Na/Ca exchange in the pancreatic B cell. Studies with thapsigargin and caffeine. *Biochem Pharmacol* 45:7–11, 1993
 56. Fenwick EM, Marty A, Neher E: A patch-clamp study of bovine chromaffin cells and of their sensitivity to acetylcholine. *J Physiol* 331:577–597, 1982
 57. Willmott NJ, Galione A, Smith PA: A cADP-ribose antagonist does not inhibit secretagogue-, caffeine- and nitric oxide-induced Ca²⁺ responses in rat pancreatic β -cells. *Cell Calcium* 18:411–419, 1995
 58. Chapman S, Smith PA, Ashcroft FM: Mobilization of intracellular calcium by caffeine in single mouse pancreatic β cells. *J Physiol* 487P:12–13, 1995
 59. Roe MW, Lancaster ME, Mertz RJ, Worley JF, Dukes ID: Voltage-dependent intracellular calcium release from mouse islets stimulated by glucose. *J Biol Chem* 268:9953–9956, 1993
 60. Hain J, Onoue H, Mayrleitner M, Fleischer S, Schindler H: Phosphorylation modulates the function of the calcium release channel of sarcoplasmic reticulum from cardiac muscle. *J Biol Chem* 270:2074–2081, 1995
 61. Herson PS, Dulock KA, Ashford ML: Characterization of a nicotinamide-adenine dinucleotide-dependent cation channel in the CRI-G1 rat insulinoma cell line. *J Physiol* 505:65–76, 1997
 62. Seino-Umeda A, Fang YI, Ishibashi M, Kobayashi J, Ohizumi Y: 9-Methyl-7-bromo-eudistomin D induces Ca²⁺ release from cardiac sarcoplasmic reticulum. *Eur J Pharmacol* 357:261–265, 1998
 63. Westerblad H, Andrade FH, Islam MS: Effects of ryanodine receptor agonist 4-chloro-*m*-cresol on myoplasmic free Ca²⁺ concentration and force of contraction in mouse skeletal muscle. *Cell Calcium* 24:105–115, 1998
 64. Li G, Wollheim CB, Pralong WF: Oscillations of cytosolic free calcium in bombesin-stimulated HIT-T15 cells. *Cell Calcium* 19:535–546, 1996
 65. Mears D, Zimlik C, Cotterell A, Atwater I: Effect of ryanodine receptor agonist 4-chloro-*m*-cresol on stimulus secretion coupling in the pancreatic β -cells (Abstract). *Diabetes* 48:A443, 1999
 66. Gromada J, dissing s, Bokvist K, Renstrom E, Frokjaer-Jensen J, Wulff BS, Rorsman P: Glucagon-like peptide I increases cytoplasmic calcium in insulin-secreting β TC3-cells by enhancement of intracellular calcium mobilization. *Diabetes* 44:767–774, 1995
 67. Ahmed M, Grapengiesser E: Pancreatic β -cells from obese-hyperglycemic mice are characterized by excessive firing of cytoplasmic Ca²⁺ transients. *Endocrine* 15:73–78, 2001
 68. Alonso MT, Barrero MJ, Michelena P, Carnicero E, Cuchillo I, Garcia AG, Garcia-Sancho J, Montero M, Alvarez J: Ca²⁺-induced Ca²⁺ release in chromaffin cells seen from inside the ER with targeted aequorin. *J Cell Biol* 144:241–254, 1999
 69. Lacabartz-Porret C, Corvazier E, Kovacs T, Bobe R, Bredoux R, Launay S, Papp B, Enouf J: Platelet sarco/endoplasmic reticulum Ca²⁺ATPase isoform 3b and Rap 1b: interrelation and regulation in physiopathology. *Biochem J* 332:173–181, 1998
 70. Supattapone S, Danoff SK, Thiebert A, Joseph SK, Steiner J, Snyder SH: Cyclic AMP-dependent phosphorylation of a brain inositol triphosphate receptor decreases its release of calcium. *Proc Natl Acad Sci U S A* 85:8747–8750, 1988
 71. Giovannucci DR, Groblewski GE, Sneyd J, Yule DI: Targeted phosphorylation of inositol 1,4,5-trisphosphate receptors selectively inhibits localized Ca²⁺ release and shapes oscillatory Ca²⁺ signals. *J Biol Chem* 275:33704–33711, 2000
 72. Xu L: *Study of the Regulation of Intracellular Calcium by Membrane Electrical Activity and cAMP in Pancreatic Beta Cells*. PhD thesis. Houston, TX, University of Houston, 1995
 73. Grapengiesser E, Gylfe E, Dansk H, Hellman B: Nitric oxide induces synchronous Ca²⁺ transients in pancreatic β cells lacking contact. *Pancreas* 23:387–392, 2001
 74. Xu L, Eu JP, Meissner G, Stamler JS: Activation of the cardiac calcium release channel (ryanodine receptor) by poly-S-nitrosylation. *Science* 279:234–237, 1998
 75. Abramson JJ, Zable AC, Favero TG, Salama G: Thimerosal interacts with the Ca²⁺ release channel ryanodine receptor from skeletal muscle sarcoplasmic reticulum. *J Biol Chem* 270:29644–29647, 1995
 76. Clementi E: Role of nitric oxide and its intracellular signalling pathways in the control of Ca²⁺ homeostasis. *Biochem Pharmacol* 55:713–718, 1998
 77. Galione A, White A, Willmott N, Turner M, Potter BVL, Watson SP: cGMP mobilizes intracellular Ca²⁺ in sea urchin eggs by stimulating cyclic ADP-ribose synthesis. *Nature* 365:456–459, 1993
 78. Oyadomari S, Takeda K, Takiguchi M, Gotoh T, Matsumoto M, Wada I, Akira S, Araki E, Mori M: Nitric oxide-induced apoptosis in pancreatic β cells is mediated by the endoplasmic reticulum stress pathway. *Proc Natl Acad Sci U S A* 98:10845–10850, 2001
 79. Lee HC: Physiological functions of cyclic ADP-ribose and NAADP as calcium messengers. *Annu Rev Pharmacol Toxicol* 41:317–345, 2001
 80. Islam MS, Berggren PO: Cyclic ADP-ribose and the pancreatic β cell: where do we stand? *Diabetologia* 40:1480–1484, 1997
 81. Okamoto H, Takasawa S, Nata K: The CD38-cyclic ADP-ribose signalling system in insulin secretion: molecular basis and clinical implications. *Diabetologia* 40:1485–1491, 1997
 82. Varadi A, Rutter GA: Dynamic imaging of endoplasmic reticulum [Ca²⁺] in insulin secreting MIN6 cells using recombinant targeted cameleons: roles of SERCA2 and ryanodine receptors. *Diabetes* 51 (Suppl. 1):S190–S201, 2002
 83. Sitsapesan R, McGarry SJ, Williams AJ: Cyclic ADP-ribose competes with ATP for the adenine nucleotide binding site on the cardiac ryanodine receptor Ca²⁺-release channel. *Circ Res* 75:596–600, 1994
 84. An NH, Han MK, Um C, Park BH, Park BJ, Kim HK, Kim UH: Significance of ecto-cyclase activity of cd38 in insulin secretion of mouse pancreatic islet cells. *Biochem Biophys Res Commun* 282:781–786, 2001
 85. Matschinsky FM, Collins HW: Essential biochemical design features of the fuel-sensing system in pancreatic β -cells. *Chem Biol* 4:249–257, 1997
 86. Henquin JC: Triggering and amplifying pathways of regulation of insulin secretion by glucose. *Diabetes* 49:1751–1760, 2000
 87. Ma J, Fill M, Knudson CM, Campbell KP, Coronado R: Ryanodine receptor of skeletal muscle is a gap junction-type channel. *Science* 242:99–102, 1988
 88. Rojas E, Carroll PB, Ricordi C, Boschero AC, Stojilkovic SS, Atwater I: Control of cytosolic free calcium in cultured human pancreatic β -cells occurs by external calcium-dependent and independent mechanisms. *Endocrinology* 134:1771–1781, 1994
 89. Kermode H, Williams AJ, Sitsapesan R: The interactions of ATP, ADP, and inorganic phosphate with the sheep cardiac ryanodine receptor. *Biophys J* 74:1296–1304, 1998
 90. Dukes ID, Sreenan S, Roe MW, Levisetti M, Zhou YP, Ostrega D, Bell GI, Pontoglio M, Yaniv M, Philipson L, Polonsky KS: Defective pancreatic β -cell glycolytic signaling in hepatocyte nuclear factor-1 α -deficient mice. *J Biol Chem* 273:24457–24464, 1998
 91. Kermode H, Chan WM, Williams AJ, Sitsapesan R: Glycolytic pathway intermediates activate cardiac ryanodine receptors. *FEBS Lett* 431:59–62, 1998
 92. Chini EN, Dousa TP: Differential effect of glycolytic intermediaries upon cyclic ADP-ribose-, inositol 1',4',5'-triphosphate-, and nicotinate adenine dinucleotide phosphate-induced Ca²⁺ release systems. *Arch Biochem Biophys* 370:294–299, 1999
 93. Lubell A, Chandarana H, Rana RS: Glycolytic metabolites and intracellular signaling in the pancreatic β cell. *Arch Biochem Biophys* 364:178–184, 1999
 94. Corkey BE, Deeney JT, Yaney GC, Tornheim K, Prentki M: The role of long-chain fatty acyl-CoA esters in β -cell signal transduction. *J Nutr* 130:299S–304S, 2000
 95. Kato I, Yamamoto Y, Fujimura M, Noguchi N, Takasawa S, Okamoto H: CD38 disruption impairs glucose-induced increases in cyclic ADP-ribose, [Ca²⁺]_i, and insulin secretion. *J Biol Chem* 274:1869–1872, 1999
 96. Scruel O, Wada T, Kontani K, Sener A, Katada T, Malaisse WJ: Effects of D-glucose and starvation upon the cyclic ADP-ribose content of rat pancreatic islets. *Biochem Mol Biol Int* 45:783–790, 1998
 97. Graeff R, Lee HC: A novel cycling assay for cellular cADP-ribose with nanomolar sensitivity. *Biochem J* 361:379–384, 2002
 98. Ainscow EK, Rutter GA: Mitochondrial priming modifies Ca²⁺ oscillations and insulin secretion in pancreatic islets. *Biochem J* 353:175–180, 2001
 99. Guo X, Przywara DA, Wakade TD, Wakade AR: Exocytosis coupled to mobilization of intracellular calcium by muscarine and caffeine in rat chromaffin cells. *J Neurochem* 67:155–162, 1996
 100. Atwater I, Ribalet B: Theophylline inhibition and stimulation of glucose-induced electrical activity in mouse pancreatic β -cells (Abstract). *J Physiol* 291:P55, 1979
 101. Ashcroft SJ, Bassett JM, Randle PJ: Isolation of human pancreatic islets capable of releasing insulin and metabolising glucose in vitro. *Lancet* i:888–889, 1971
 102. Turtle JR, Littleton GK, Kipnis DM: Stimulation of insulin secretion by theophylline. *Nature* 213:727–728, 1967
 103. McDaniel ML, Weaver DC, Roth CE, Fink CJ, Swanson JA, Lacy PE: Characterization of the uptake of the methylxanthines theophylline and caffeine in isolated pancreatic islets and their effect on D-glucose transport. *Endocrinology* 101:1701–1708, 1977
 104. Kolehmainen E: Mechanism of the myelin basic protein-induced insulin and glucagon release from isolated rat pancreatic islets. *Neurochem Int* 26:357–367, 1995

105. Shi CL. Effects of caffeine and acetylcholine on glucose-stimulated insulin release from islet transplants in mice. *Cell Transplant* 6:33–37, 1997
106. Brisson GR, Malaisse-Lagae F, Malaisse WJ: The stimulus-secretion coupling of glucose-induced insulin release. VII. A proposed site of action for adenosine-3',5'-cyclic monophosphate. *J Clin Invest* 51:232–241, 1972
107. Lefebvre P, Luyckx A: Effects of imidazole and 2 of its derivatives on the secretion of insulin in the anesthetized dog. *C.R. Acad Sci Hebd Seances Acad Sci D* 272:498–500, 1971
108. Schmidt HH, Warner TD, Ishii K, Sheng H, Murad F: Insulin secretion from pancreatic B cells caused by L-arginine-derived nitrogen oxides. *Science* 255:721–723, 1992
109. Sjöholm Å: Nitric oxide donor SIN-1 inhibits insulin release. *Am J Physiol* 271:C1098–C1102, 1996
110. Malaisse WJ, Malaisse-Lagae F, King S: Effects of neutral red and imidazole upon insulin secretion. *Diabetologia* 4:370–374, 1968
111. Janjic D, Wollheim CB, Sharp GWG: Selective inhibition of glucose-stimulated insulin release by dantrolene. *Am J Physiol* 243:E59–E67, 1982
112. Pian-Smith MC, Wiedenkeller DE, Sharp GW: Paradoxical potentiation of stimulated insulin release by dantrolene in rat pancreatic islets. *Pancreas* 1:501–508, 1986
113. Islam MS, Berggren PO: Depolarization-evoked Ca^{2+} signalling in pancreatic β -cells is amplified by calcium-induced calcium release (Abstract). *Diabetologia* 41 (Suppl. 1):A37, 1998
114. Nakagaki I, Sasaki S, Hori S, Kondo H: Ca^{2+} and electrolyte mobilization following agonist application to the pancreatic β cell line HIT. *Pflugers Arch* 440:828–834, 2000
115. Kang G, Holz GG: Dual signaling capacity of Ca^{2+} -induced Ca^{2+} release as a stimulus for exocytosis and endocytosis in pancreatic β -cells (Abstract). *Biophys J* 82:3006, 2002
116. Holz GG, Kuhlreiber WM, Habener JF: Pancreatic β -cells are rendered glucose-competent by the insulinotropic hormone glucagon-like peptide-1(7-37). *Nature* 361:362–365, 1993
117. Augustine GJ, Neher E: Calcium requirements for secretion in bovine chromaffin cells. *J Physiol* 450:247–271, 1992
118. Abdel-Halim SM, Guenifi A, Khan A, Larsson O, Berggren PO, Östenson CG, Efendic S: Impaired coupling of glucose signal to the exocytotic machinery in diabetic GK rats: a defect ameliorated by cAMP. *Diabetes* 45:934–940, 1996
119. Varadi A, Molnar E, Östenson CG, Ashcroft SJ: Isoforms of endoplasmic reticulum Ca^{2+} -ATPase are differentially expressed in normal and diabetic islets of Langerhans. *Biochem J* 319:521–527, 1996
120. Maechler P, Kennedy ED, Sebo E, Valeva A, Pozzan T, Wollheim CB: Secretagogues modulate the calcium concentration in the endoplasmic reticulum of insulin-secreting cells: studies in aequorin-expressing intact and permeabilized INS-1 cells. *J Biol Chem* 274:12583–12592, 1999
121. Graves TK, Hinkle PM: Depolarization causes calcium induced calcium release in insulinoma cells (Abstract). *Diabetologia* 44 (Suppl. 1):A126, 2001
122. Zeng XH, Qu AL, Lou XL, Xu JH, Wang JJ, Wu HX, Zhou ZA: Ca^{2+} signals induced from calcium stores in pancreatic islet β cells. *Chinese Sci Bull* 45:51–56, 2000