

## Mutations in the Insulin Gene can Cause MODY and Autoantibody-Negative Type 1 Diabetes

Anders Molven,<sup>1,2</sup> Monika Ringdal,<sup>3,4</sup> Anita M. Nordbø,<sup>3,4</sup> Helge Ræder,<sup>5</sup> Julie Støy,<sup>6</sup> Gregory M. Lipkind,<sup>8</sup> Donald F. Steiner,<sup>6,8</sup> Louis H. Philipson,<sup>6</sup> Ines Bergmann,<sup>9</sup> Dagfinn Aarskog,<sup>10</sup> Dag E. Undlien,<sup>11,12</sup> Geir Joner,<sup>13,14</sup> Oddmund Søvik,<sup>3</sup> the Norwegian Childhood Diabetes Study Group\*, Graeme I. Bell,<sup>6,7</sup> and Pål R. Njølstad<sup>3,5</sup>  
\*Other members of the Norwegian Childhood Diabetes Study Group are listed in the appendix at the end of the paper.

From the <sup>1</sup>Gade Institute, University of Bergen, Norway; the <sup>2</sup>Department of Pathology, Haukeland University Hospital, Bergen, Norway; the <sup>3</sup>Department of Clinical Medicine, University of Bergen, Bergen, Norway; the <sup>4</sup>Center for Medical Genetics and Molecular Medicine, Haukeland University Hospital, Bergen, Norway; the <sup>5</sup>Department of Pediatrics, Haukeland University Hospital, Bergen, Norway; the Departments of <sup>6</sup>Medicine, <sup>7</sup>Human Genetics and <sup>8</sup>Biochemistry and Molecular Biology, The University of Chicago, Chicago, Illinois, USA; <sup>9</sup>Kristiansund Hospital, Kristiansund, Norway; <sup>10</sup>Buskerud Hospital, Drammen, Norway; the <sup>11</sup>Institute of Medical Genetics, Faculty Division, Ullevål University Hospital, University of Oslo, Oslo, Norway; the <sup>12</sup>Department of Medical Genetics, Ullevål University Hospital, Oslo, Norway; the <sup>13</sup>Department of Pediatrics, Ullevål University Hospital, Oslo, Norway; and the <sup>14</sup>Faculty of Medicine, University of Oslo, Oslo, Norway.

### Corresponding Author:

Dr. Pål R. Njølstad  
Department of Pediatrics, Haukeland University Hospital,  
N-5021 Bergen, Norway.  
pal.njolstad@uib.no

Received for publication 14 October 2007 and accepted in revised form 6 January 2008.

## ABSTRACT

*Objective:* Mutations in the insulin (*INS*) gene can cause neonatal diabetes. We hypothesized that mutations in *INS* could also cause MODY and autoantibody-negative type 1 diabetes.

*Research Design And Methods:* We screened *INS* in 62 probands with MODY, 30 probands with suspected MODY, and 223 subjects from the Norwegian Childhood Diabetes Registry selected on the basis of auto-antibody negativity or family history of diabetes.

*Results:* Among the MODY patients, we identified the *INS* mutation c.137G>A (R46Q) in a proband, his diabetic father and a paternal aunt. They were diagnosed with diabetes at 20, 18 and 17 years of age, respectively, and are treated with small doses of insulin or diet only. In type 1 diabetes patients, we found the *INS* mutation c.163C>T (R55C) in a girl who 10 years old presented with ketoacidosis and insulin-dependent, GAD and IA-2 antibody-negative diabetes. Her mother had a *de novo* R55C mutation and was diagnosed with ketoacidosis and insulin-dependent diabetes at 13 years of age. Both had residual  $\beta$ -cell function. The R46Q substitution changes an invariant arginine residue in position B22, which forms a hydrogen bond with the glutamate at A17 stabilizing the insulin molecule. The R55C substitution involves the first of the two arginine residues localized at the site of proteolytic processing between the B-chain and the C-peptide.

*Conclusions:* Our findings extend the phenotype of *INS* mutation carriers and suggest that *INS* screening is warranted not only in neonatal diabetes, but also in MODY and in selected cases of type 1 diabetes.

**ABBREVIATIONS.** BMI, body mass index; GAD, glutamic acid decarboxylase; GCK, glucokinase; HNF, hepatocyte nuclear factor; IA-2, insulinoma-associated antigen-2; *INS*, insulin; MODY, maturity-onset diabetes of the young

**M**olecular genetic studies of monogenic forms of diabetes such as MODY and neonatal diabetes have provided important insight into the pathophysiology and led to improved diagnosis and treatment (1-7). In type 1 diabetes, immune-mediated destruction of the pancreatic  $\beta$ -cells plays an important role in the pathogenesis (8). However, some type 1 diabetic children do not present with signs of autoimmunity and are classified as having autoantibody-negative type 1 diabetes, also denoted idiopathic or type 1b diabetes (9-11). Recently, we observed that heterozygous missense mutations in the insulin gene (*INS*) can cause permanent neonatal diabetes (12). The majority of these mutations occurred *de novo*. Moreover, this phenomenon has been noted in previous studies of *KCNJ11* and *ABCC8* in patients with neonatal diabetes, and is in accordance with the sporadic nature of permanent neonatal diabetes.

We hypothesized that *INS* mutations might also cause MODY and could explain some cases of apparent type 1 diabetes. The aim of the present study was therefore to search for *INS* mutations in patients with MODY of unknown etiology as well as in selected patients from the Norwegian Childhood Diabetes Registry.

## RESEARCH DESIGN AND METHODS

**Subjects.** Physicians refer subjects to the Norwegian MODY Registry based on at least two of the following criteria: 1) first-degree relative with diabetes; 2) onset of diabetes before 25 years of age in at least one family member; 3) insulin requirement < 0.5 U/kg/day; 4) diabetes diagnosed between age 25 and 40 years of age; and 5) subjects with an unusual type 1 diabetes (low dose insulin requirement, no antibodies, atypical history). The conventional criteria of MODY (13) are therefore not met in all cases. Still, inclusion of subjects based strictly on the conventional criteria would exclude some true MODY patients, e.g. those with *de*

*novo* mutations, age at diagnosis older than 25 years or limited clinical data on the family history of diabetes. We screened DNA samples from 92 probands of the Norwegian MODY Registry for mutations in *INS*. Sixty-two fulfilled conventional MODY criteria, while 30 were categorized as “suspected MODY”. None of the probands had mutations in *HNF1A* (14). Moreover, 57 of the probands had a phenotype clinically evaluated as MODY2-like. *GCK* mutations had therefore been excluded in them. Standard oral glucose tolerance testing was performed, and WHO criteria for diabetes were applied.

In addition, we investigated samples from the population-based Norwegian Childhood Diabetes Registry (15). From June 2002 to June 2007, 1,373 subjects were eligible and enrolled. We excluded subjects with mutations in *HNF1A* or *KCNJ11*, and one subject with diabetes secondary to pancreatectomy. We then chose to screen two subsets of subjects in the present study. The first consisted of patients who were glutamic acid decarboxylase isoform 65 (GAD) and insulinoma-associated antigen-2 (IA-2) antibody-negative, with or without a family history of diabetes (n = 124). The second subset consisted of GAD and/or IA-2 antibody-positive patients with at least one parent with diabetes (n = 99). Antibodies were measured the day after diagnosis. We used the following cut-offs to define antibody status as negative: GAD less than 0.08 units and IA-2 less than 0.1 units. Diabetes in the parents included all types of diabetes. Thus, we sequenced *INS* in a total of 223 subjects regarded as having type 1 diabetes. The reference ranges for fasting C-peptide was 220-1400 pmol/L for subjects in the MODY family N580 and 400-1700 pmol/L for subjects in the type 1 diabetes family N781.

We obtained written informed consent from all participants or their parents. The study was approved by the Regional Committee for Research Ethics and the Norwegian Data Inspectorate, and

performed according to the Helsinki Declaration.

**Genotyping.** DNA was purified from EDTA-blood samples by standard methods. Human *INS* was amplified in two segments using PCR and the primers 5'-CAAGGGCCTTTGCGTCA-3' together with 5'-GAAGCCAACACCGTCCTCA-3' (exon 2), and 5'-CCCTGACTGTGTCCTCCTGT-3' together with 5'-AGAGAGCGTGGAGAGAGCTG-3' (exon 3). The exon and flanking non-coding region of *INS* were sequenced in both directions using an Applied Biosystems 3730 DNA Analyzer (Applied Biosystems, Foster City, CA). We imported all sequence sample files into the SeqScape® Software (Applied Biosystems) and analyzed for variation in *INS*. Template sequence applied for *INS* was NM\_000207 (NCBI database).

## RESULTS

***INS* mutations and MODY.** We did not find any pathogenic mutations in the 30 subjects with suspected MODY. We did, however, find a heterozygous mutation in one of the 62 families fulfilling conventional MODY criteria (Fig. 1A; Table 1). The mutation, c.137G>A, is predicted to alter arginine to glutamine at residue number 46 (R46Q) of the preproinsulin molecule (Fig. 2). The proband (N580-1) was diagnosed with diabetes at 20 years of age. Initially, he was treated with diet only. After one year, he needed psychopharmacologic treatment, BMI increased to 29.6 kg/m<sup>2</sup> and he required insulin. Subsequently, his psychopharmacologic treatment was changed; he lost weight and is now on diet only. N580-1 was GAD and IA-2 antibody-negative. Non-fasting C-peptide was undetectable. Recent HbA<sub>1c</sub> was 5.9 % (normal range 4.0-6.0 %). His father (N580-3) was diagnosed with diabetes at 18 years of age. He was initially treated with diet only. After about 20 years, sulfonylurea was introduced. In later years, he has been treated with small doses of insulin. The proband's paternal aunt (N580-4) was

diagnosed with diabetes at 17 years of age. She has had a strict diet without need for pharmacological treatment.

***INS* mutations and type 1 diabetes.** Nearly all Norwegian subjects diagnosed with diabetes at age 18 years or less are included in the Norwegian Childhood Diabetes Registry. We first screened *INS* in a group of 124 antibody-negative cases, and found a heterozygous mutation in one proband. The mutation, c.163C>T, is predicted to cause an arginine to cysteine substitution at residue 55 (R55C) of the preproinsulin molecule (Fig. 2). We subsequently sequenced a further 99 subjects with antibody-positive type 1 diabetes and a parental history of diabetes, but identified no further mutations.

The subject N781-1 with the R55C mutation presented with frank diabetes at 10 years of age (Fig. 1B; Table 1). She had blood glucose of 17.6 mmol/L, ketoacidosis and her HbA<sub>1c</sub> was 9.1% (normal range 4.0-6.2). Autoantibodies against insulin were 5.8 U/ml (normal range < 1.0) while fasting C-peptide was detectable (500 pmol/L). She was insulin-dependent from the time of diagnosis. Her most recent insulin requirement and HbA<sub>1c</sub> were 0.72 U/kg/day and 8.0 %, respectively. A recent meal-stimulated C-peptide was detectable (1050 pmol/L; paired glucose 9.6 mmol/L). Recent autoantibodies against insulin were positive (6.3 U/mL), while GAD and IA-2 were negative. Her mother (N781-3) had type 1 diabetes diagnosed at 13 years of age (Table 1). She is presently treated with insulin (0.96 U/kg/day). Recent meal-stimulated C-peptide was barely detectable (420 pmol/L; paired glucose 11.1 mmol/L). Recent autoantibodies against insulin were positive (5.8 U/mL), while GAD and IA-2 were negative. She also carries the heterozygous mutation. The proband's maternal grandfather (N781-6) has type 2 diabetes diagnosed at 40 years of age. He is treated with insulin (0.47 U/kg/day). Recent HbA<sub>1c</sub> was 6.4 %. His current BMI is 42.7 kg/m<sup>2</sup> and he has nephropathy, retinopathy and neuropathy. Neither he nor the healthy

maternal grandmother are mutation carriers. Thus, the proband's mother has a *de novo* mutation. The paternal uncle (N781-5) was diagnosed with type 2 diabetes at 50 years of age. He is treated with glimepiride (2 mg/day). Recent HbA<sub>1c</sub> was 7.3 %, and BMI was 21.4 kg/m<sup>2</sup>. He is not carrying the mutation.

***The pathogenic role of the INS mutations R46Q and R55C.*** We did not detect either mutation among 100 healthy blood donors. Neither mutation has been described previously (12,16). The mutation R46Q alters an invariant arginine at residue 22 of the B-chain. The guanidino group of arginine forms a hydrogen bond with the glutamate at residue 17 of the A-chain and participates in a network of electrostatic interactions with surrounding carbonyl and carboxyl oxygens which stabilizes the structure of the insulin molecule (Fig. 3). The substitution of arginine B22 by glutamine will disrupt this critical hydrogen bond. The mutation R55C affects the first of the two arginines at the B-chain – C-peptide junction, i.e. the first site of proteolytic processing of proinsulin to insulin. The substitution of arginine with a neutral residue (in this case cysteine) is not predicted to interfere with the proteolytic processing by proinsulin endoprotease PC1/3. It is thus more likely that the introduction of an unpaired cysteine may affect insulin biosynthesis as noted for C96Y, the mutant insulin in the Akita mouse, by introducing a defect in folding of the preproinsulin molecule (12,17). Both carriers of the R55C mutation have C-peptide levels in the normal range, thus suggesting that some insulin is being processed and secreted. It is currently not fully understood why these patients, despite evidence of insulin secretion, have severe insulin deficiency as indicated by ketoacidosis at diagnosis and subsequent requirement for insulin in full replacement doses.

## DISCUSSION

We have found that mutations in the gene encoding insulin can cause MODY and antibody-negative type 1 diabetes. Our findings add *INS* to the list of causes for MODY which includes *HNF4A*, *GCK*, *HNF1A*, *IPF1*, *HNF1B*, *NEUROD1* and *CEL*. The relatively mild phenotype of the three family members with the R46Q mutation suggests that a spectrum of phenotypes may exist in patients with *INS* mutations; ranging from mild diabetes and hyperinsulinemia in patients with the previously described mutations that cause reduced biological activity of the insulin molecule (i.e. B24 Ser, B25 Leu and A3 Leu) (18,19), to MODY in patients with mutations that are predicted to reduce the structural stability of the insulin molecule (R46Q), and ultimately to neonatal diabetes in patients with mutations that cause severe defects in the biosynthesis of the insulin molecule (for example B8 Ser and B19 Gly) (12).

One could argue that the case with apparent type 1 diabetes (R55C) was MODY that was misclassified. The presentation, however, was like classical type 1 diabetes with ketoacidosis and frank diabetes. Hence, we believe that most pediatricians on a clinical basis will classify such a patient as having type 1 diabetes. Not all clinics are routinely screening children with newly developed diabetes for antibodies. Although rare, we nevertheless think it is interesting that patients with a monogenic form of diabetes can be found amongst those with a diagnosis of type 1 diabetes, an observation that has important implications for diagnosis, genetic counseling and possibly for treatment.

Generally, subjects with neonatal diabetes and *INS* mutations are small for gestational age (12,16). None of our five mutation-positive subjects had low birth weights (Fig. 1). The R46Q mutation of family N580 appears to be functionally mild compared to the *INS* mutations causing neonatal diabetes, as suggested by the much later age of onset, a low HbA<sub>1c</sub> and less

intensive treatment needed. The effect of R46Q on fetal insulin secretion may therefore be negligible, explaining the lack of effect on birth weight. In family N781, the diabetic mother with a *de novo* mutation had a birth weight in the lower normal range. The relatively high birth weight of her R55C-carrying child can be explained by the mother being diabetic during pregnancy and a near-normal insulin secretion capacity in fetal life. As for R46Q, the age of onset suggests that the phenotype of R55C is milder than that of *INS* mutations causing neonatal diabetes.

Although 80% of the *INS* cases found in patients with neonatal diabetes are *de novo*, both the probands described here inherited the mutation from a diabetic parent. Thus, our findings as well as those of Edghill et al. (16) indicate that *de novo* mutations in the *INS* gene are possible when diabetes presents after the neonatal period.

In summary, our results suggest that patients with MODY and autoantibody-negative type 1 diabetes should be screened for mutations in *INS*. The presence of residual  $\beta$ -cell function in the subjects with apparent type 1 diabetes indicates that new approaches for treatment should be considered in such cases with *INS* mutations.

## ACKNOWLEDGEMENTS

This study was supported by the University of Bergen, Haukeland University Hospital, Helse Vest, Innovest and the Functional Genomics Programme (FUGE) of the Research Council of Norway. Research carried out in Chicago was supported by U.S. Public Health Service Grants DK-13914, DK-20595, DK-44752, DK-73541, and DK-77489 and a gift from the Kovler Family Foundation.

## OTHER MEMBERS OF THE NORWEGIAN CHILDHOOD DIABETES STUDY GROUP

The following physicians also contributed to the study: Henning Aabech and Sven Simonsen, Fredrikstad; Helge Vogt, Lørenskog; Kolbeinn Gudmundsson, Anne Grethe Myhre, Knut Dahl-Jørgensen, Oslo; Jon Grøtta, Elverum; Ola Tallerås and Dag Helge Frøisland, Lillehammer; Halvor Bævre, Gjøvik; Kjell Stensvold, Drammen; Bjørn Halvorsen, Tønsberg; Kristin Hodnekvam, Skien; Ole Kr. Danielsen, Arendal; Jorunn Ulriksen and Unni Mette Köpp, Kristiansand; Jon Bland, Stavanger; Dag Roness, Haugesund; Per Helge Kvistad, Førde; Steinar Spangen, Ålesund; Per Erik Hæreid, Trondheim; Sigurd Børsting, Levanger; Dag Veimo, Bodø; Harald Dramsdahl, Harstad; Bård Forsdahl, Tromsø; Kersti Elisabeth Thodenius and Ane Kokkvoll, Hammerfest.

## REFERENCES

1. Yamagata K, Furuta H, Oda N, Kaisaki PJ, Menzel S, Cox NJ, Fajans SS, Signorini S, Stoffel M, Bell GI: Mutations in the hepatocyte nuclear factor-4alpha gene in maturity-onset diabetes of the young (MODY1). *Nature* 384:458-460, 1996
2. Yamagata K, Oda N, Kaisaki PJ, Menzel S, Furuta H, Vaxillaire M, Southam L, Cox RD, Lathrop GM, Boriraj VV, Chen X, Cox NJ, Oda Y, Yano H, Le Beau MM, Yamada S, Nishigori H, Takeda J, Fajans SS, Hattersley AT, Iwasaki N, Hansen T, Pedersen O, Polonsky KS, Turner R, Velho G, Chevre J-C, Froguel P, Bell GI: Mutations in the hepatocyte nuclear factor-1alpha gene in maturity-onset diabetes of the young (MODY3). *Nature* 384:455-458, 1996
3. Froguel P, Zouali H, Vionnet N, Velho G, Vaxillaire M, Sun F, Lesage S, Stoffel M, Takeda J, Passa P, Permutt MA, Beckmann JS, Bell GI, Cohen D: Familial hyperglycemia due to mutations in glucokinase. Definition of a subtype of diabetes mellitus. *N Engl J Med* 328:697-702, 1993
4. Njølstad PR, Søvik O, Cuesta-Munoz A, Bjørkhaug L, Massa O, Barbetti F, Undlien DE, Shiota C, Magnuson MA, Molven A, Matschinsky FM, Bell GI: Neonatal diabetes mellitus due to complete glucokinase deficiency. *N Engl J Med* 344:1588-1592, 2001
5. Gloyn AL, Pearson ER, Antcliff JF, Proks P, Bruining GJ, Slingerland AS, Howard N, Srinivasan S, Silva JM, Molnes J, Edghill EL, Frayling TM, Temple IK, Mackay D, Shield JP, Sumnik Z, van Rhijn A, Wales JK, Clark P, Gorman S, Aisenberg J, Ellard S, Njølstad PR, Ashcroft FM, Hattersley AT: Activating mutations in the gene encoding the ATP-sensitive potassium-channel subunit Kir6.2 and permanent neonatal diabetes. *N Engl J Med* 350:1838-1849, 2004
6. Sagen JV, Ræder H, Hathout E, Shehadeh N, Gudmundsson K, Bævre H, Abuelo D, Phornphutkul C, Molnes J, Bell GI, Gloyn AL, Hattersley AT, Molven A, Søvik O, Njølstad PR: Permanent neonatal diabetes due to mutations in KCNJ11 encoding Kir6.2: patient characteristics and initial response to sulfonylurea therapy. *Diabetes* 53:2713-2718, 2004
7. Pearson ER, Flechtner I, Njølstad PR, Malecki MT, Flanagan SE, Larkin B, Ashcroft FM, Klimes I, Codner E, Iotova V, Slingerland AS, Shield J, Robert JJ, Holst JJ, Clark PM, Ellard S, Søvik O, Polak M, Hattersley AT: Switching from insulin to oral sulfonylureas in patients with diabetes due to Kir6.2 mutations. *N Engl J Med* 355:467-477, 2006
8. Pihoker C, Gilliam LK, Hampe CS, Lernmark A: Autoantibodies in diabetes. *Diabetes* 54 Suppl 2:S52-61, 2005
9. American Diabetes Association: Report of the Expert Committee on the Diagnosis and Classification of Diabetes Mellitus. *Diabetes Care* 20:1183-1197, 1997
10. American Diabetes Association: Diagnosis and classification of diabetes mellitus. *Diabetes Care* 27 Suppl 1:S5-S10, 2004
11. Edghill EL, Dix RJ, Flanagan SE, Bingley PJ, Hattersley AT, Ellard S, Gillespie KM: HLA genotyping supports a nonautoimmune etiology in patients diagnosed with diabetes under the age of 6 months. *Diabetes* 55:1895-1898, 2006
12. Støy J, Edghill EL, Flanagan SE, Ye H, Paz VP, Pluzhnikov A, Below JE, Hayes MG, Cox NJ, Lipkind GM, Lipton RB, Greeley SA, Patch AM, Ellard S, Steiner DF, Hattersley AT, Philipson LH, Bell GI: Insulin gene mutations as a cause of permanent neonatal diabetes. *Proc Natl Acad Sci U S A* 104:15040-15044, 2007
13. Fajans SS, Bell GI, Polonsky KS: Molecular mechanisms and clinical pathophysiology of maturity-onset diabetes of the young. *N Engl J Med* 345:971-980, 2001
14. Bjørkhaug L, Sagen JV, Thorsby P, Søvik O, Molven A, Njølstad PR: Hepatocyte nuclear factor-1 alpha gene mutations and diabetes in Norway. *J Clin Endocrinol Metab* 88:920-931, 2003

15. Bjørnvold M, Amundsen SS, Stene LC, Joner G, Dahl-Jørgensen K, Njølstad PR, Ek J, Ascher H, Gudjonsdottir AH, Lie BA, Skinningsrud B, Akselsen HE, Rønningen KS, Sollid LM, Undlien DE: FOXP3 polymorphisms in type 1 diabetes and coeliac disease. *J Autoimmun* 27:140-144, 2006
16. Edghill EL, Flanagan SE, Patch AM, Boustred C, Parrish A, Shields B, Shepherd MH, Hussain K, Kapoor RR, Malecki M, Macdonald MJ, Støy J, Steiner DF, Philipson LH, Bell GI; the Neonatal Diabetes International Collaborative Group, Hattersley AT, Ellard S: Insulin mutation screening in 1044 patients with diabetes: Mutations in the INS gene are a common cause of neonatal diabetes but a rare cause of diabetes diagnosed in childhood or adulthood. *Diabetes* 2007, Dec 27; [Epub ahead of print]
17. Liu M, Hodish I, Rhodes CJ, Arvan P: Proinsulin maturation, misfolding, and proteotoxicity. *Proc Natl Acad Sci U S A* 104:15841-15846, 2007
18. Tager H, Given B, Baldwin D, Mako M, Markese J, Rubenstein A, Olefsky J, Kobayashi M, Kolterman O, Poucher R: A structurally abnormal insulin causing human diabetes. *Nature* 281:122-125, 1979
19. Steiner DF, Tager HS, Nanjo K, Chan SJ, Rubenstein AH. Familial syndromes of hyperproinsulinemia and hyperinsulinemia with mild diabetes. In *The Metabolic Basis of Inherited Disease*, 7th ed. Scriver CR, Beaudet AL, Sly WS, Valle D, Eds. New York, McGraw-Hill, 1995, p. 897-904

**TABLE 1.** Clinical characteristics of the subjects with the *INS* mutations R46Q and R55C

Family	MODY-N580			T1D-N781	
Subject	N580-1	N580-3	N580-4	N781-1	N781-3
General Characteristics					
<i>INS</i> mutation	R46Q	R46Q	R46Q	R55C	R55C
Sex	M	M	F	F	F
Current age (years)	25	61	59	12	40
Centile for birth weight	+1.5 SDS	+1 SDS	-1.5 SDS	> +2 SDS	+0 SDS
Onset of diabetes					
Age (years)	20	18	17	10	13
Clinical manifestation	Hyperglycemia	Glucosuria	Glucosuria	Hyperglycemia, ketoacidosis	Hyperglycemia, ketoacidosis
Recent status					
BMI (kg/m <sup>2</sup> )	23.9	25.0	18.1	24.6	37.6
HbA <sub>1c</sub> (%)	5.9	6.0	6.0	8.0	8.9
Insulin dose (U/kg/day)	None (diet-treated)	0.25	None (diet-treated)	0.72	0.96
Other	Bipolar disorder	Neuropathy Hypertension	-	-	-

NA = not available, SDS = standard deviation score

## FIGURE LEGENDS

**Figure 1.** Mutations in *INS* can cause MODY and type 1 diabetes. *A:* Pedigree of a family with MODY due to the mutation R46Q. The three cases of diabetes in the first generation were unavailable for genetic analysis, but for one of them limited clinical information could be obtained. *B:* Pedigree of a family with antibody-negative type 1 diabetes and the mutation R55C. For both pedigrees, current age, birth weight / gestational age, age of diagnosis, current treatment and mutation status are listed. Subjects with diabetes are shown in black. Females are represented by circles and males by squares. The probands are marked by arrows. Abbreviations: NA, not available; NGT, normal glucose tolerance; OHA, oral hypoglycemic agents; T1DM, type 1 diabetes mellitus; T2DM, type 2 diabetes mellitus.

**Figure 2.** *A:* DNA sequences of the *INS* mutations c.137G>A (R46Q) and c.163C>T (R55C) found in the Norwegian Childhood Diabetes Registry and the Norwegian MODY Registry, respectively. *B:* Location of the two corresponding amino acid substitutions in the preproinsulin molecule. The ten mutations identified by Støy et al. (12) are shown in smaller font. Amino acid numbers below the bars show the extension of each peptide fragment in preproinsulin. Note that the amino acids 55/56 and 88/89 form the recognition sites for the proteolytic removal of the C-peptide, but are not part of the mature insulin molecule. 'S-S' indicates disulfide bridge.

**Figure 3.** Predicted effect of the R46Q mutation on structural stability of the insulin molecule. *A:* The native structure of insulin, shown by space-filled image, where the side chain of arginine B22 (B22R) forms a hydrogen bond with the side chain of glutamate A17 (A17E). This hydrogen bond stabilizes the C-terminal ends of the A- and B-chains (shown by red and blue ribbons, respectively). *B:* Effect of mutating the arginine to glutamine at B22 (B22Q). Substitution of the long side chain of arginine by the 4.5 Å shorter side chain of glutamine disrupts the formation of a hydrogen bond between residues B22 and A17. B22R is invariant, while A17 tolerates only two stereochemically equivalent amino acid residues, glutamate and glutamine, both which allow the hydrogen bond between B22 and A17.

FIGURE 1

**A** Family MODY-N580

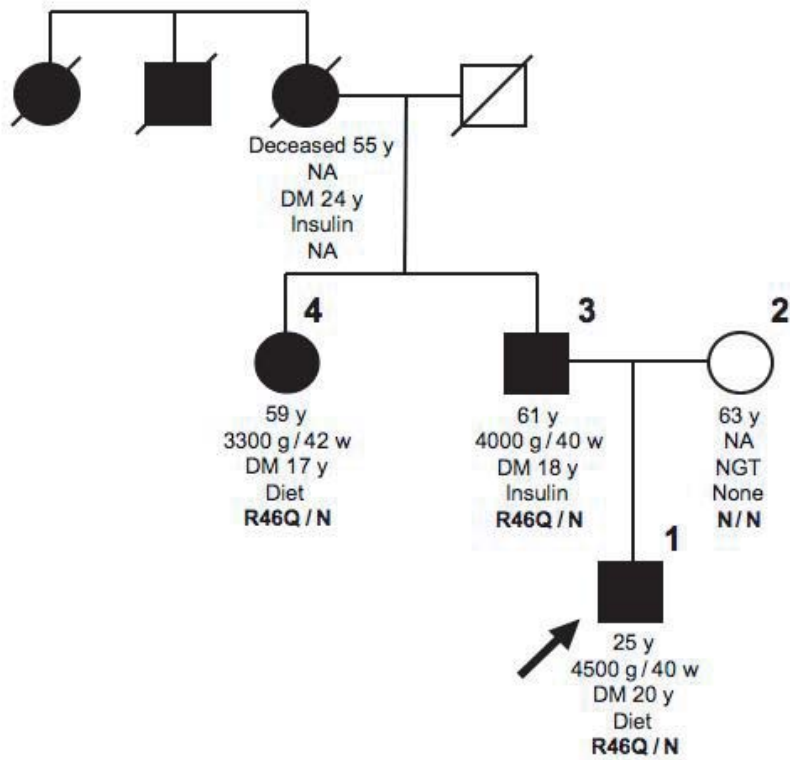

**B** Family T1D-N781

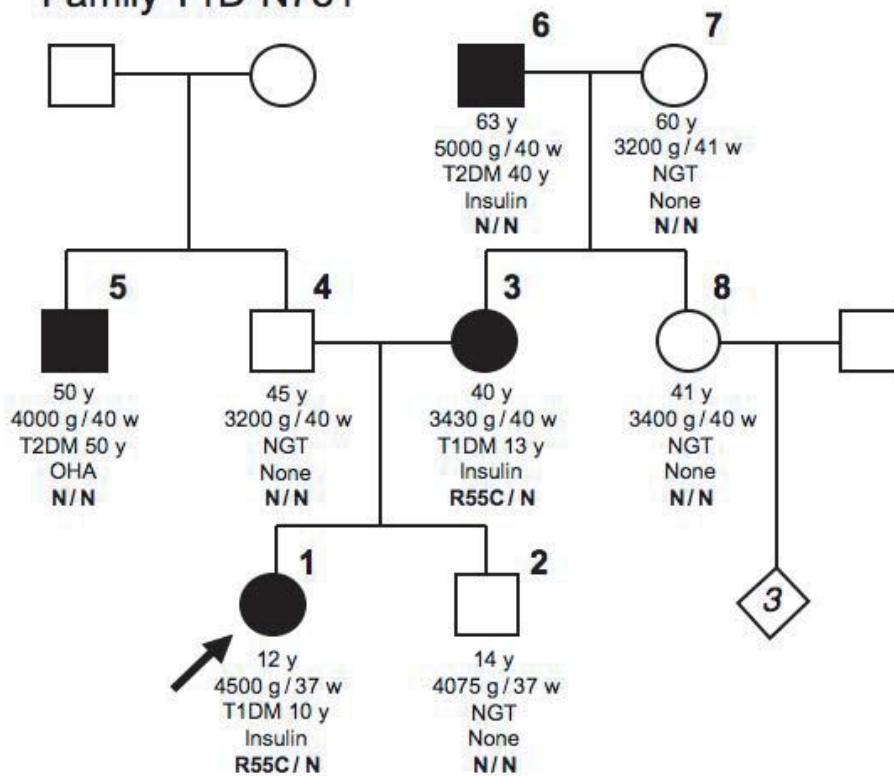
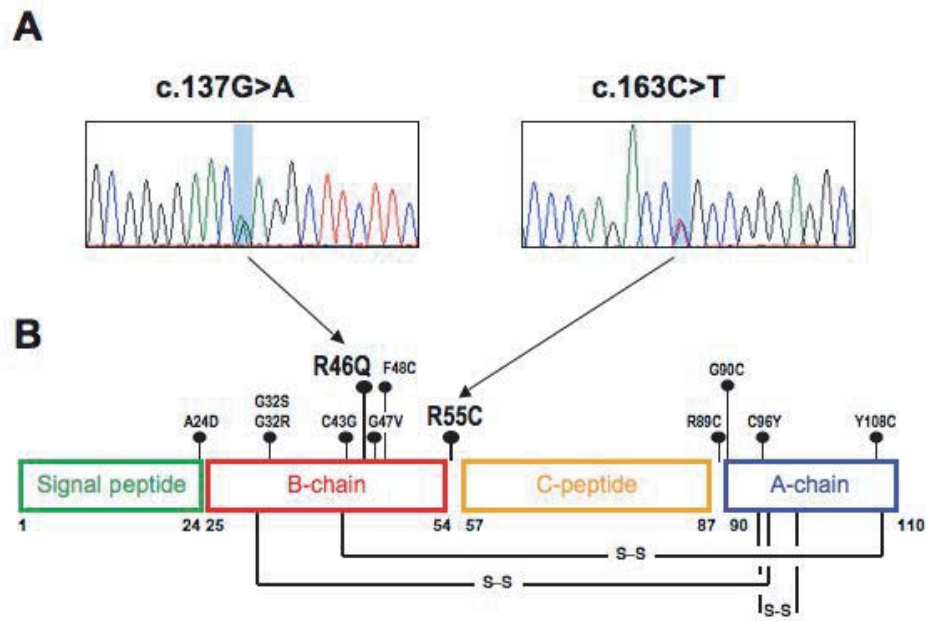

FIGURE 2



**FIGURE 3**

